

MicrobialControl

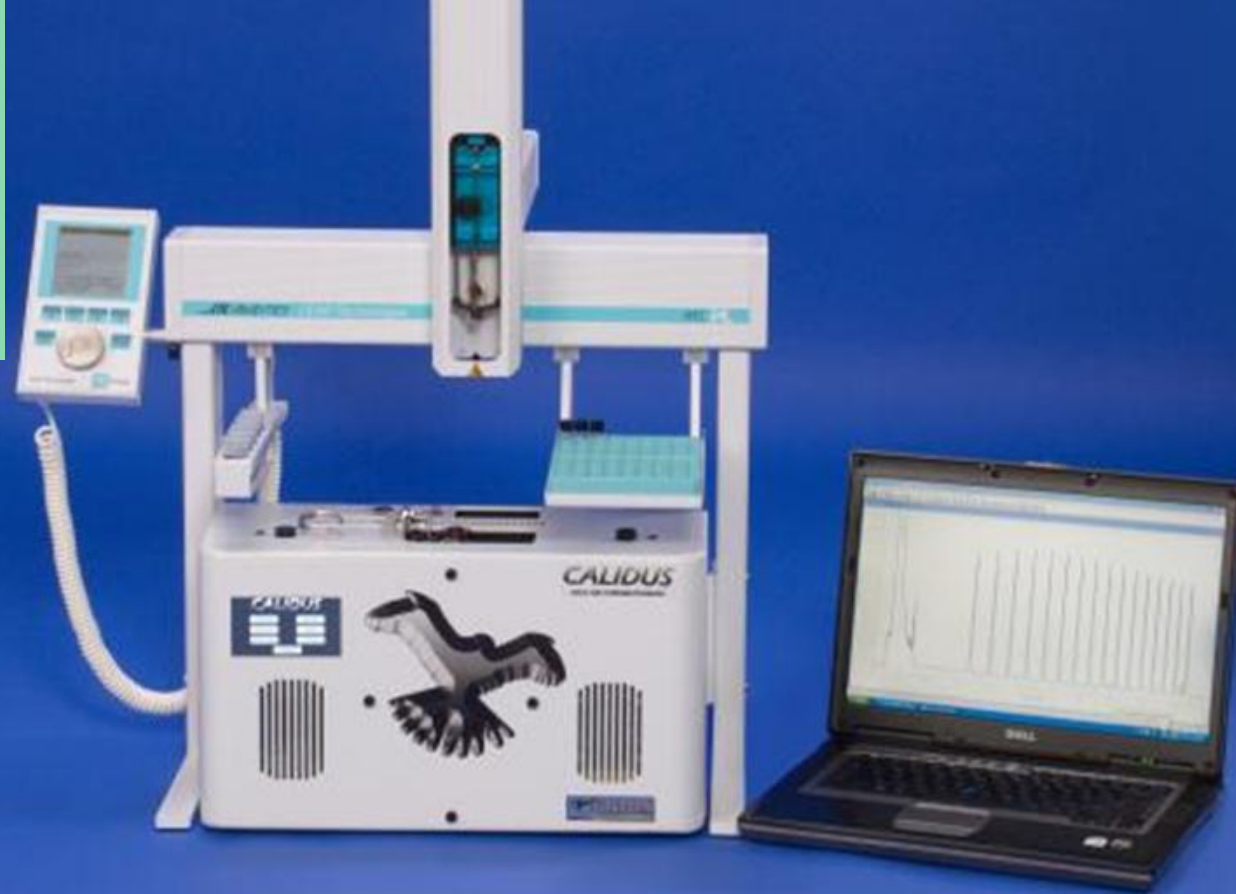

Improved Batch Process Throughput with Fast, Automated Food Grade Fatty Acid Endpoint Analysis

Jonathan Blackwell,
Production Process Manager/ OE Specialist, Lonza, Williamsport

Lonza

The Problem

- Legacy Product Certificate of Analysis Requirements
 - Contracts require continuity when implementing new analysis technology
 - Results based on years old technique were still desired
 - Older technology limited analytical improvements and therefore process improvements

- Requirements for moving forward
 - Faster sample preparation
 - Faster analysis
 - Automation
 - Results “the same as before”

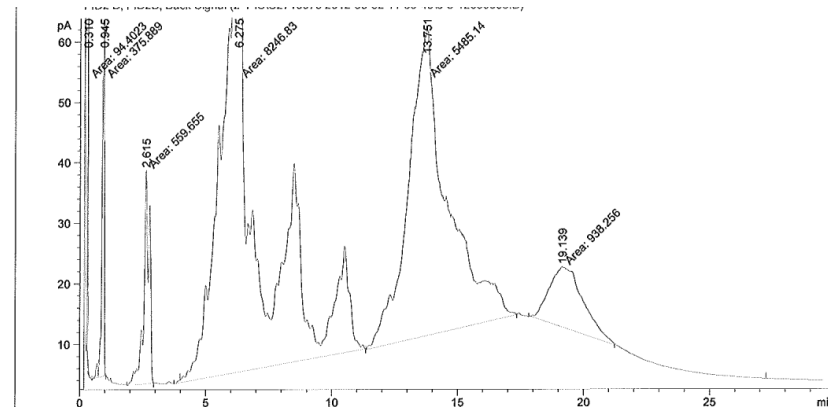

The Solution

- Feasibility testing was done on all seven samples
 - Quick methyl ester sample preparations
 - Quick analysis using fast and micro gas chromatography
 - Integration technique to match legacy results and
 - Automation possibilities were explored
 - Sample preparation (derivatization of fatty acids to methyl esters)
 - Seven individual sample analysis methods on one micro and fast GC
 - Integration and reporting

- The results...
 - All testing demonstrated a high probability of successful implementation

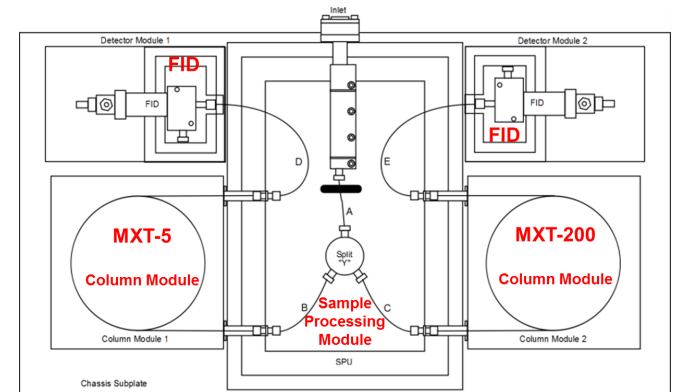

Example of Feasibility Runs... Polyglycerol Esters, the Worst Case

- First, derivatizations via silylation
- Second, sample injections
- Third, separations
- Fourth, integrations
- Finally, calculations & result
- Is continuity possible?

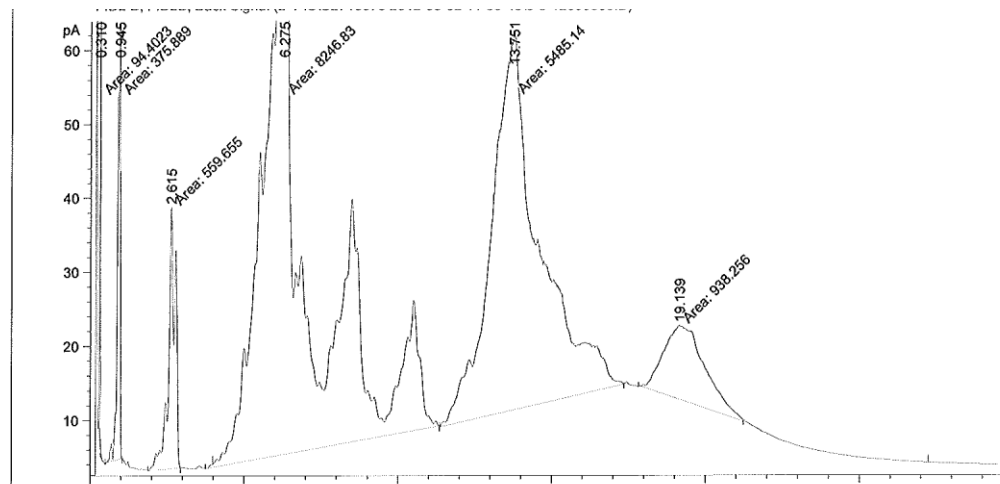

Quick & Dirty Scouting Procedure

- Polyglycerol Ester was heated to the melting point
- Derivatization agent was added and simply shaken
- The resultant solution was injected soon after
 - ~ 100 nanoliters hand injection
 - Split injection was used
 - Rapid programmed temperature profile
 - Flame Ionization Detector was used
- Preparation included running a boiling range distribution standard

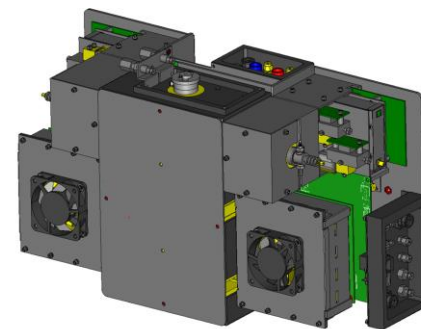

Establish Boiling Range n-C₅ – n-C₄₄ in Mineral Spirits

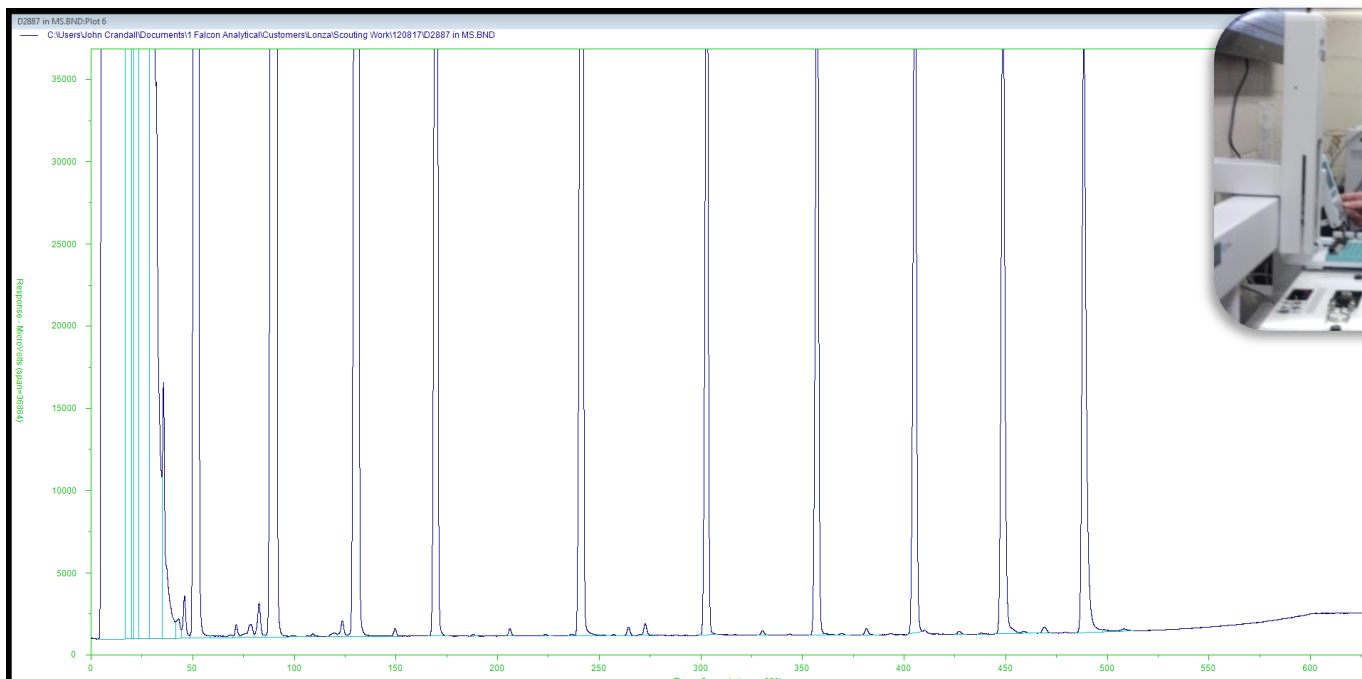

Correlates retention time to boiling point. n-C₄₄ is 535°C.

Polyglycerol Ester

■ Notes

- Resolution is similar with better peak shapes
- Run time is about 700 seconds, compared to 35 minutes
- Also, note some high boiling mass is missing.

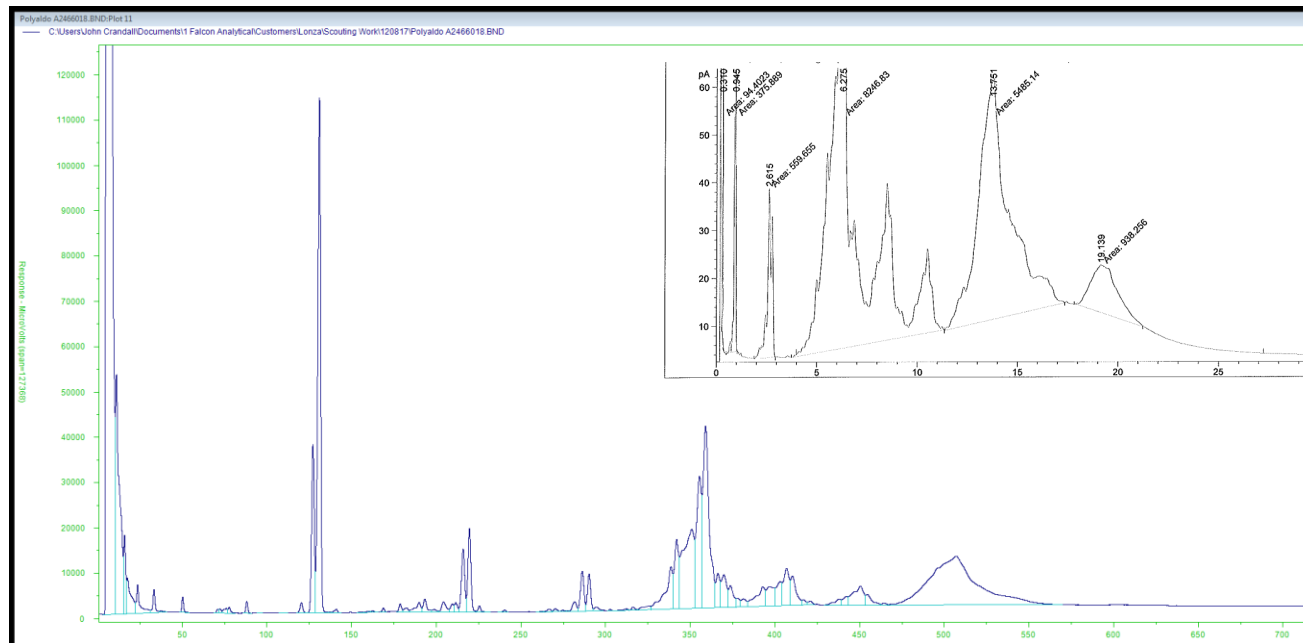

Polyglycerol Ester Overlaid n-C₅ – n-C₄₄

■ Notes

- The boiling range goes beyond the n-C₄₄ standard
- The missing mass appears to go up to about n-C₅₀ in boiling point
- The injection exhibited some high boiling point discrimination.

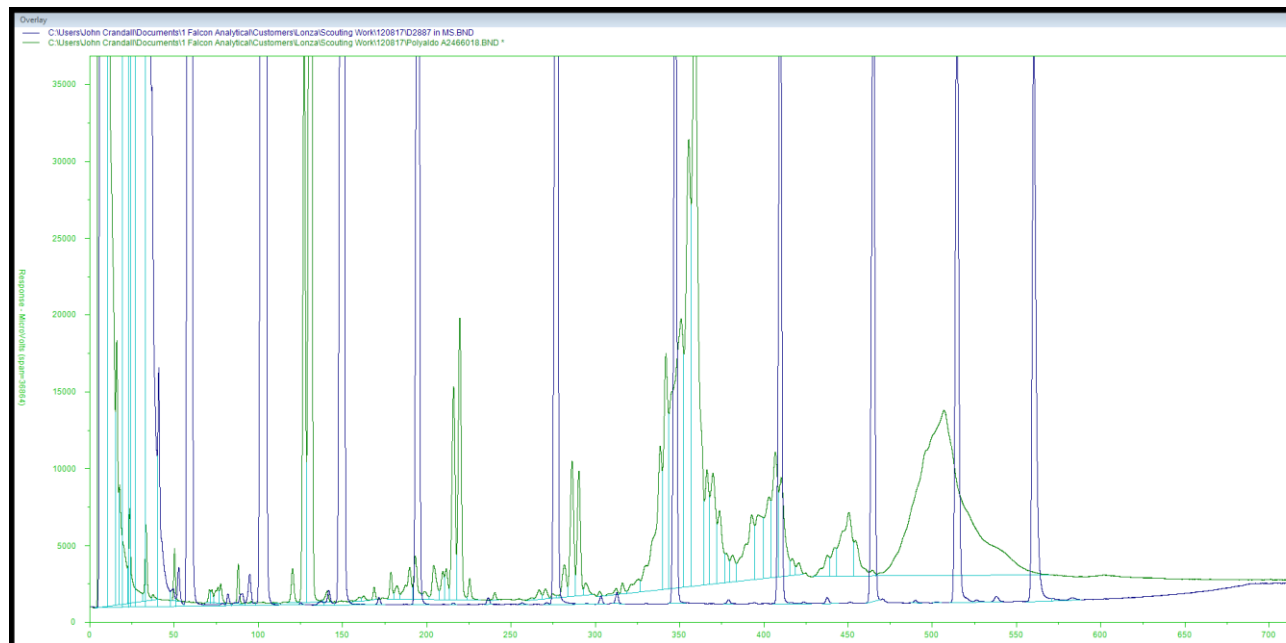

Polyglycerol Ester Zoomed

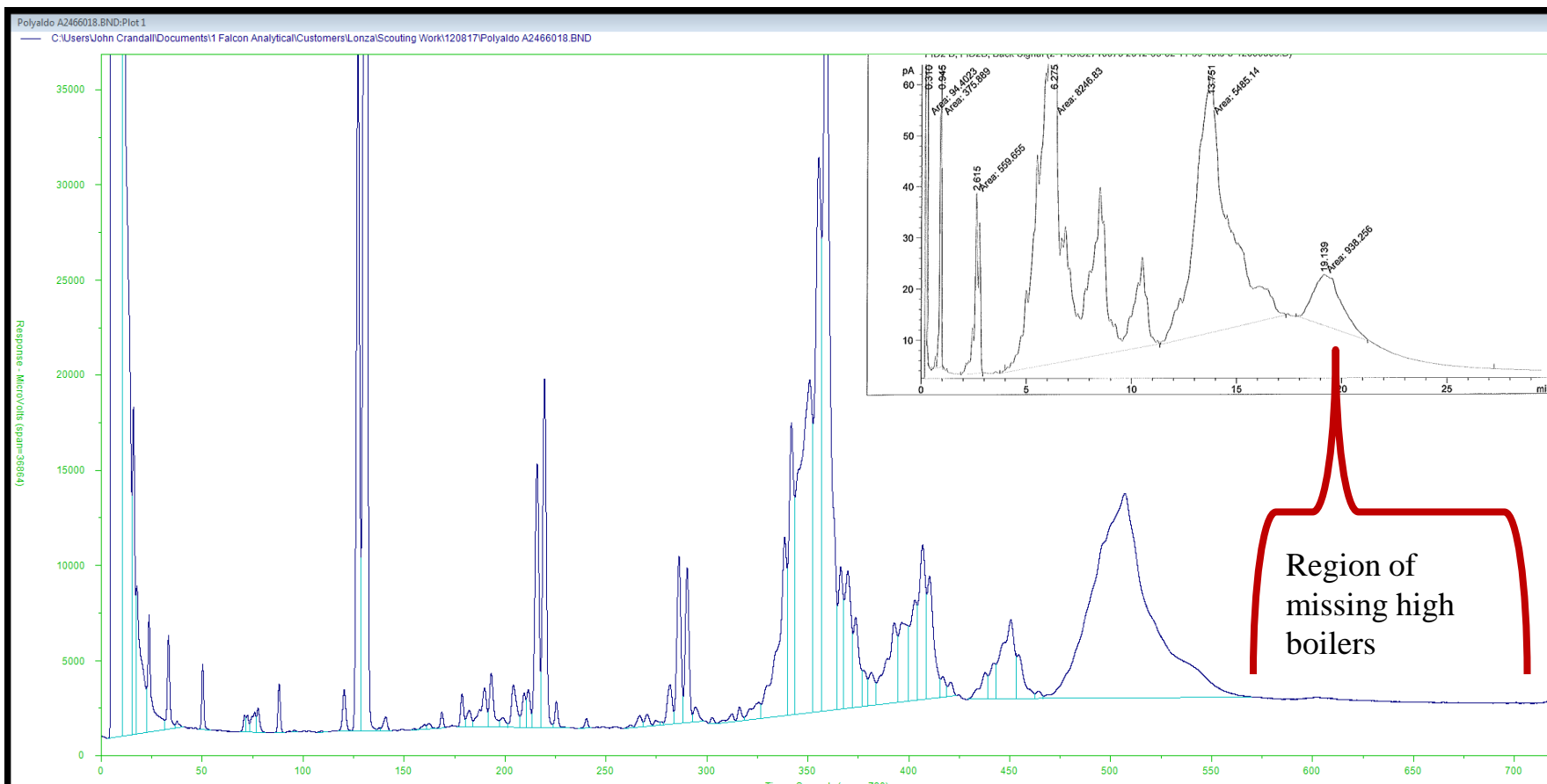

Resolution of the Discrimination Problem

■ Inlet

- The inlet temperature was raised
- The slit ratio was optimized
- Sample processing module transfer line temperatures were increased
- The inlet glass liner type was changed

■ Injection technique

- Hand injections were found to be unsuitable
- LEAP autosampler was deployed
 - Syringe loading method was developed demonstrating that
 - Injection depth, dwell time, plunger speed and needle withdrawal are all important to elimination of the discrimination.

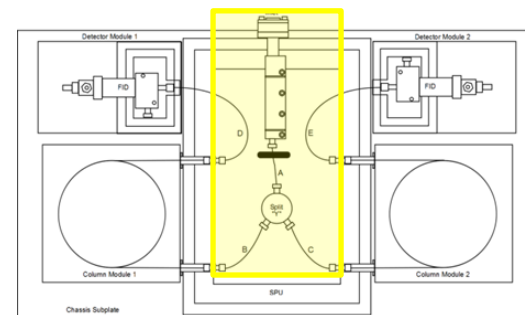

The Other 6 Were Easier... Ethoxylate Zoomed

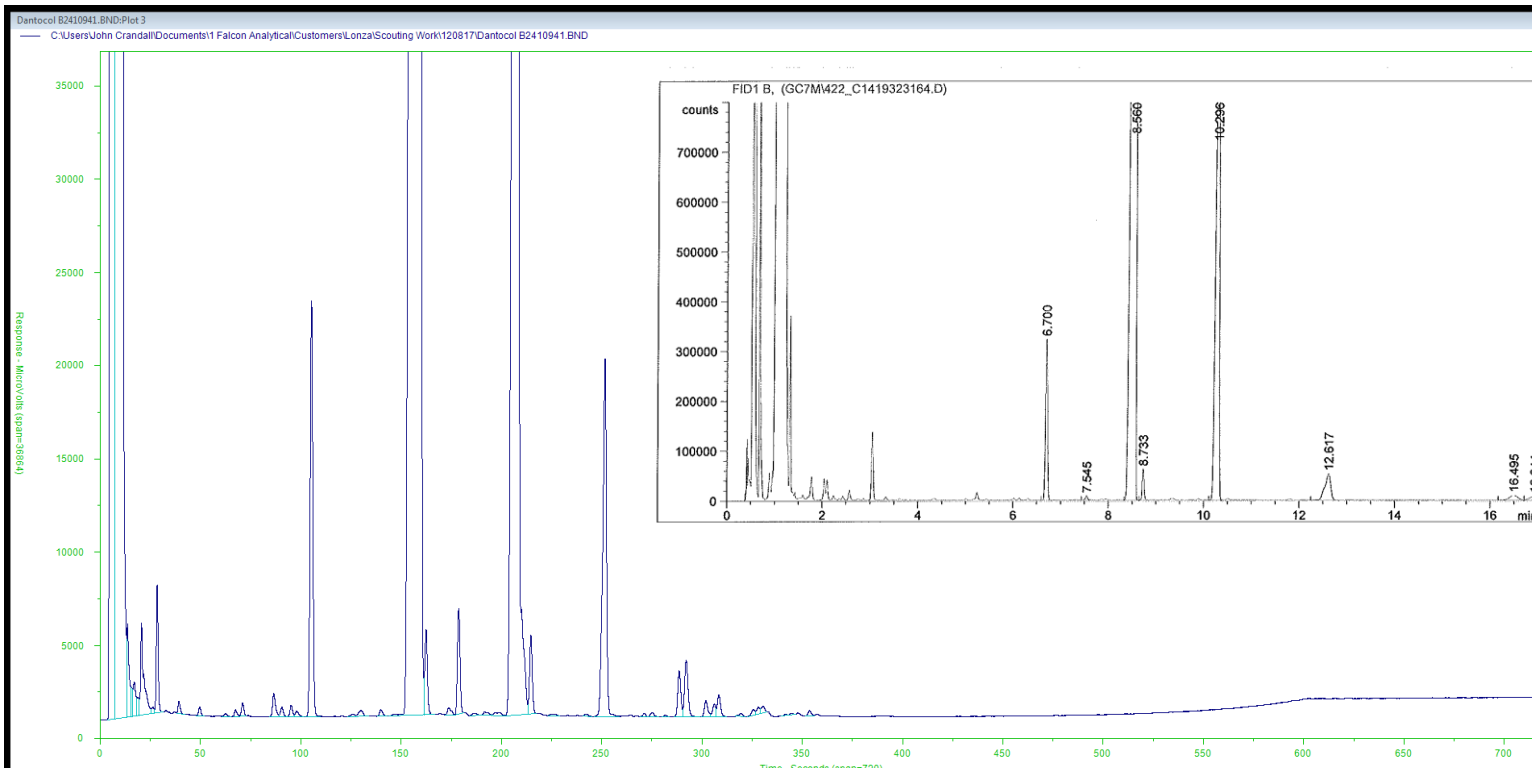

Success: 7 Sample Types, 7 Methods, One GC

All but the sampling and derivatization is automated with continuity with the legacy methods.

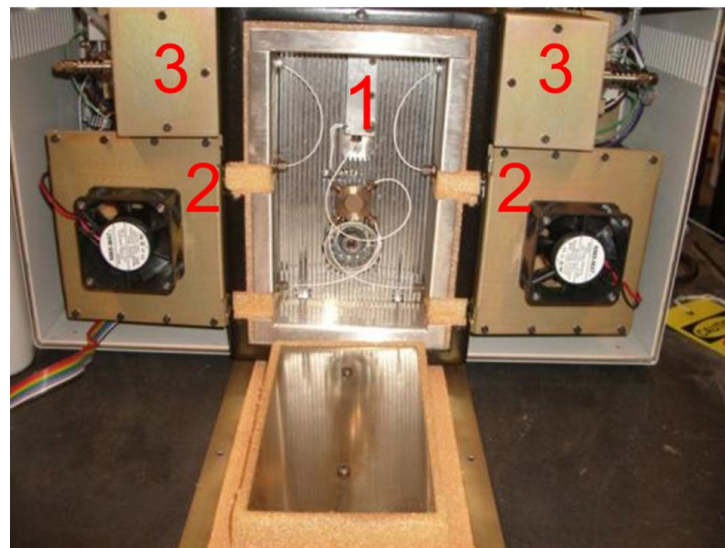
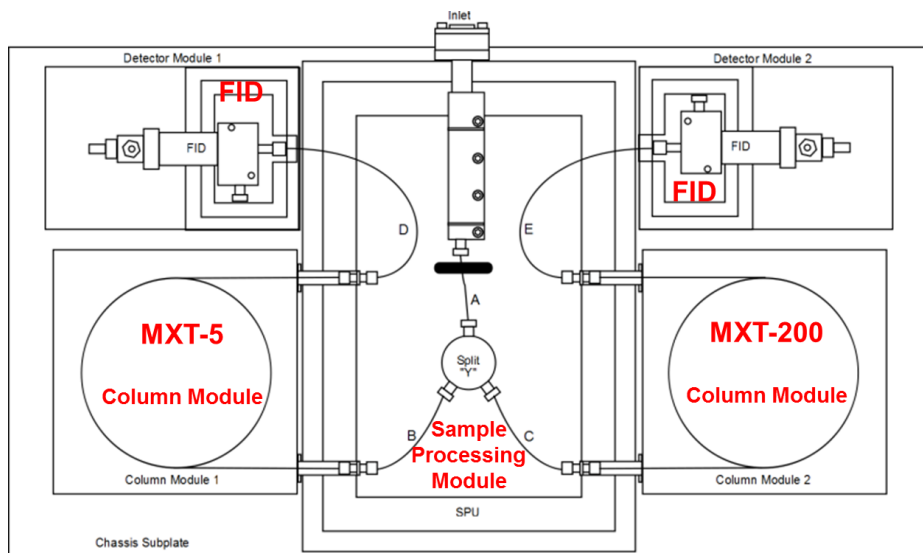

Calidus 301, single split injector, sample splitter, parallel operation of 2 Channels selected by the method chosen, dual FID detection.

System as Deployed

- The system is a Calidus 301 configured to use methods selecting one channel or the other.
- Most of the samples are run using the left Channel 1. The right Channel 2 was needed for more polar products and Hot Oil (ppm) Analysis
- Next steps possible
 - Automate derivatization with the autosampler
 - Other applications throughout the plant

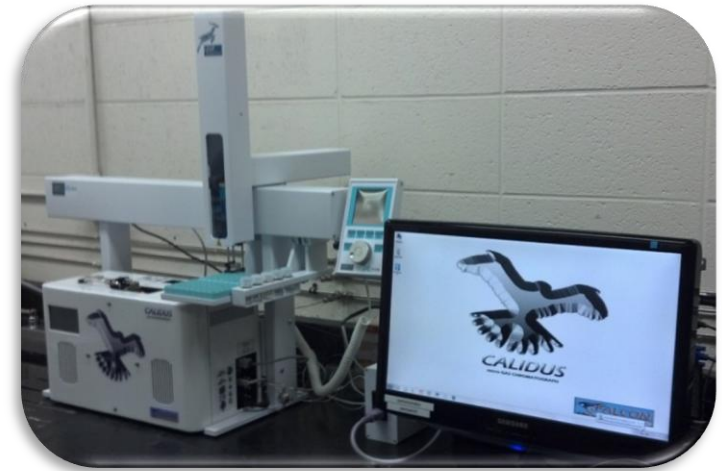

Value to Lonza

- Calidus bridges the gap between online process control and R&D
 - The at-line deployment optimizes implementation for batch processes
 - Rapid results improve process control and optimizes use of the reactor
- Analysis isn't the only speed enhancing parameter
 - Sample preparation technique is faster
 - Automated integration saves time too
- Overall the system brings more economic analysis information to process operations saving significant process time per batch and an estimated annual value in the hundreds of thousands of dollars (savings and added capacity).

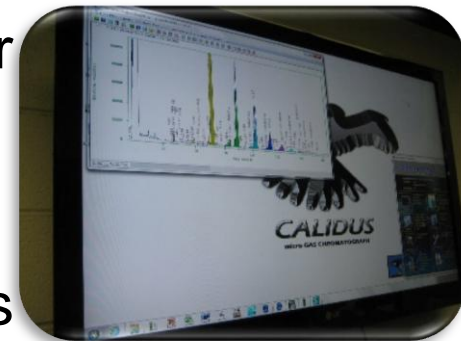

Thank You!

Any Questions?

- **Jonathan Blackwell**
- **Production Process Manager/ OE Specialist**
Lonza, Inc.

