

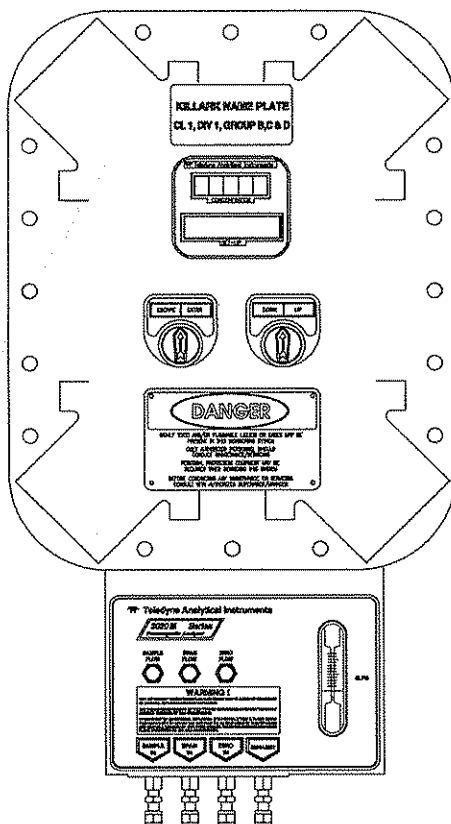

**Use and Disclosure of Data**  
Information contained herein is classified as EAR99 under the  
U.S. Export Administration Regulations.  
Export, reexport or diversion contrary to U.S. law is prohibited.

## OPERATING INSTRUCTIONS FOR

# Model 3020M

## Percent Paramagnetic Oxygen Analyzer



 **DANGER** 

HIGHLY TOXIC AND OR FLAMMABLE LIQUIDS OR GASES MAY BE PRESENT IN THIS MONITORING SYSTEM.

PERSONAL PROTECTIVE EQUIPMENT MAY BE REQUIRED WHEN SERVICING THIS SYSTEM.

HAZARDOUS VOLTAGES EXIST ON CERTAIN COMPONENTS INTERNALLY WHICH MAY PERSIST FOR A TIME EVEN AFTER THE POWER IS TURNED OFF AND DISCONNECTED.

ONLY AUTHORIZED PERSONNEL SHOULD CONDUCT MAINTENANCE AND/OR SERVICING. BEFORE CONDUCTING ANY MAINTENANCE OR SERVICING CONSULT WITH AUTHORIZED SUPERVISOR/MANAGER.

P/N M69993  
11/24/04  
ECO:#03-0126



### Copyright © 1999 Teledyne Analytical Instruments

All Rights Reserved. No part of this manual may be reproduced, transmitted, transcribed, stored in a retrieval system, or translated into any other language or computer language in whole or in part, in any form or by any means, whether it be electronic, mechanical, magnetic, optical, manual, or otherwise, without the prior written consent of Teledyne Analytical Instruments, 16830 Chestnut Street, City of Industry, CA 91749-1580.

#### Warranty

This equipment is sold subject to the mutual agreement that it is warranted by us free from defects of material and of construction, and that our liability shall be limited to replacing or repairing at our factory (without charge, except for transportation), or at customer plant at our option, any material or construction in which defects become apparent within one year from the date of shipment, except in cases where quotations or acknowledgements provide for a shorter period. Components manufactured by others bear the warranty of their manufacturer. This warranty does not cover defects caused by wear, accident, misuse, neglect or repairs other than those performed by Teledyne or an authorized service center. We assume no liability for direct or indirect damages of any kind and the purchaser by the acceptance of the equipment will assume all liability for any damage which may result from its use or misuse.

We reserve the right to employ any suitable material in the manufacture of our apparatus, and to make any alterations in the dimensions, shape or weight of any parts, in so far as such alterations do not adversely affect our warranty.

#### Important Notice

This instrument provides measurement readings to its user, and serves as a tool by which valuable data can be gathered. The information provided by the instrument may assist the user in eliminating potential hazards caused by his process; however, it is essential that all personnel involved in the use of the instrument or its interface, with the process being measured, be properly trained in the process itself, as well as all instrumentation related to it.

The safety of personnel is ultimately the responsibility of those who control process conditions. While this instrument may be able to provide early warning of imminent danger, it has no control over process conditions, and it can be misused. In particular, any alarm or control systems installed must be tested and understood, both as to how they operate and as to how they can be defeated. Any safeguards required such as locks, labels, or redundancy, must be provided by the user or specifically requested of Teledyne at the time the order is placed.

Therefore, the purchaser must be aware of the hazardous process conditions. The purchaser is responsible for the training of personnel, for providing hazard warning methods and instrumentation per the appropriate standards, and for ensuring that hazard warning devices and instrumentation are maintained and operated properly.

Teledyne Analytical Instruments, the manufacturer of this instrument, cannot accept responsibility for conditions beyond its knowledge and control. No statement expressed or implied by this document or any information disseminated by the manufacturer or its agents, is to be construed as a warranty of adequate safety control under the user's process conditions.

### Specific Model Information

The instrument for which this manual was supplied may incorporate one or more options not supplied in the standard instrument. Commonly available options are listed below, with check boxes. Any that are incorporated in the instrument for which this manual is supplied are indicated by a check mark in the box.

**Instrument Serial Number:** \_\_\_\_\_

#### Options Included in the Instrument with the Above Serial Number:

- 3020M-C:** In addition to all standard features, this model also has separate ports for zero and span gases, and built-in control valves. The internal valves are entirely under the control of the 3020M electronics, to automatically switch between gases in synchronization with the analyzer's operations
- 3020M-F:** Includes flame arrestors for Group C and D service.
- 3020M-G:** Includes flame arrestors for Groups C and D service, plus gas control valves as in -C option, above
- 3020M-H:** Includes flame arrestors for Group B (hydrogen) service.
- 3020M-I:** Includes flame arrestors for Group B (hydrogen) service, plus gas control valves as in -C option, above.

**Table of Contents**

---

**1 Introduction**

1.1 Overview ..... 1-1  
1.2 Typical Applications ..... 1-1  
1.3 Main Features of the Analyzer ..... 1-1  
1.4 Model Designations ..... 1-2  
1.5 Operator Interface ..... 1-2  
    1.5.1 UP/DOWN Switch ..... 1-4  
    1.5.2 ESCAPE/ENTER Switch ..... 1-4  
    1.5.3 Displays ..... 1-5  
1.6 Recognizing Difference Between LCD & VFD ..... 1-5  
1.7 Rear Panel (Equipment Interface) ..... 1-5  
    1.7.1 Electrical Connector Panel ..... 1-5  
    1.7.2 Gas Connector Panel ..... 1-7

**2 Operational Theory**

2.1 Introduction ..... 2-1  
2.2 Paramagnetic Sensor ..... 2-1  
    2.2.1 Principles of Operation ..... 2-1  
2.3 Cross Interference ..... 2-3  
2.4 Sample System ..... 2-5  
2.5 Electronics and Signal Processing ..... 2-6  
2.6 Temperature Control ..... 2-6

**3 Installation**

3.1 Unpacking the Analyzer ..... 3-1  
3.2 Mounting the Analyzer ..... 3-1  
3.3 Electrical Connections ..... 3-3  
    3.3.1 Primary Input Power ..... 3-4  
    3.3.2 Fuse Installation ..... 3-4  
    3.3.3 Analog Outputs ..... 3-4  
    3.3.4 Alarm Relays ..... 3-7  
    3.3.5 Digital Remote Cal Inputs ..... 3-8  
    3.3.6 Range ID Relays ..... 3-9  
    3.3.7 Network I/O ..... 3-9  
    3.3.8 RS-232 Port ..... 3-9  
    3.3.9 Remote Sensor and Solenoid Valves ..... 3-11  
3.4 Gas Connections ..... 3-12  
3.5 Testing the System ..... 3-13

## 4 Operation

4.1	Introduction .....	4-1
4.2	Using the Controls .....	4-1
4.2.1	Mode/Function Selection .....	4-2
4.2.1.1	Analysis Mode .....	4-2
4.2.1.2	Setup Mode .....	4-2
4.2.2	Data Entry .....	4-4
4.2.2.1	ENTER .....	4-4
4.2.2.2	ESCAPE .....	4-4
4.3	The AUTO-CAL Function .....	4-5
4.4	The PWD Function .....	4-5
4.4.1	Entering the Password .....	4-6
4.4.2	Installing or Changing the Password .....	4-7
4.5	The LOGOUT Function .....	4-8
4.6	The VERSION Screen .....	4-8
4.7	The SELF TEST Function .....	4-9
4.8	The SPAN Functions .....	4-9
4.8.1	Span Cal .....	4-10
4.8.1.1	Auto Mode Spanning .....	4-10
4.8.1.2	Manual Mode Spanning .....	4-11
4.9	The CAL Function .....	4-11
4.10	The ALARMS Function .....	4-13
4.11	The RANGE Function .....	4-15
4.11.1	Setting the Analog Output Ranges .....	4-16
4.11.2	Automatic Ranging .....	4-16
4.11.3	Fixed Range Analysis .....	4-16
4.12	The CONTRAST Function .....	4-17
4.13	The STANDBY Function .....	4-17
4.14	The <i>Analysis Mode</i> .....	4-18
4.15	The <i>Sensor Function</i> .....	4-18

## Maintenance

5.1	Routine Maintenance .....	5-1
5.2	Major Internal Components .....	5-1
5.3	Sensor Replacement .....	5-2
5.4	Fuse Replacement .....	5-2
5.5	System Self Diagnostic Test .....	5-3
5.6	Output Goes Negative .....	5-4

**Appendix**

A-1 Specifications ..... A-1  
A-2 Recommended 2-Year Spare Parts List ..... A-3  
A-3 Drawing List ..... A-4

## **Introduction**

---

### **1.1 Overview**

The Teledyne Analytical Instruments Model 3020M Percent Paramagnetic Oxygen Analyzer is a versatile microprocessor-based instrument for detecting oxygen in a variety of gases. This manual covers the Model 3020M, percent oxygen, explosion-proof, bulkhead-mount units only.

### **1.2 Typical Applications**

A few typical applications of the Model 3020M are:

- Monitoring inert gas blanketing
- Air separation and liquefaction
- Chemical reaction monitoring
- Semiconductor manufacturing
- Petrochemical process control
- Quality assurance
- Gas analysis certification.

### **1.3 Main Features of the Analyzer**

The Model 3020M Percent Oxygen Analyzer is sophisticated yet simple to use. The main features of the analyzer include:

- A 2-line alphanumeric display screen, driven by microprocessor electronics, that continuously prompts and informs the operator.
- High resolution, accurate readings of oxygen content from low % levels through 100%. Large, bright, meter readout.
- Stainless steel sample system.



- Versatile analysis over a wide range of applications.
- Microprocessor based electronics: 8-bit CMOS microprocessor with 32 kB RAM and 128 kB ROM.
- Three user definable output ranges (from 0-5 % through 0-100 %) allow best match to users process and equipment.
- Auto Ranging allows analyzer to automatically select the proper preset range for a given measurement. Manual override allows the user to lock onto a specific range of interest.
- Two adjustable concentration alarms and a system failure alarm.
- Extensive self-diagnostic testing, at startup and on demand, with continuous power-supply monitoring.
- RS-232 serial digital port for use with a computer or other digital communication device.
- Analog outputs for concentration and range identification. (0-1 VDC standard, and isolated 4–20 mADC)

## 1.4 Model Designations

- 3020M:** Standard model.
- 3020M-C:** In addition to all standard features, this model also has separate ports for zero and span gases, and built-in control valves. The internal valves are entirely under the control of the 3020M electronics, to automatically switch between gases in synchronization with the analyzer's operations
- 3020M-F:** Includes flame arrestors for Groups C and D.
- 3020M-G:** Includes flame arrestors for Groups C and D, & -C option.
- 3020M-H:** Includes flame arrestors for Group B (Hydrogen service).
- 3020M-I:** Includes flame arrestors for Group B, & -C option.

## 1.5 Operator Interface

All controls and displays on the standard 3020M are accessible from outside the housing. The instrument has two simple operator controls. The operator has constant feedback from the instrument through an alphanumeric display, a digital oxygen meter, and a sample flow meter. The displays and

controls are described briefly here and in greater detail in chapter 4. See Figure 1-1.

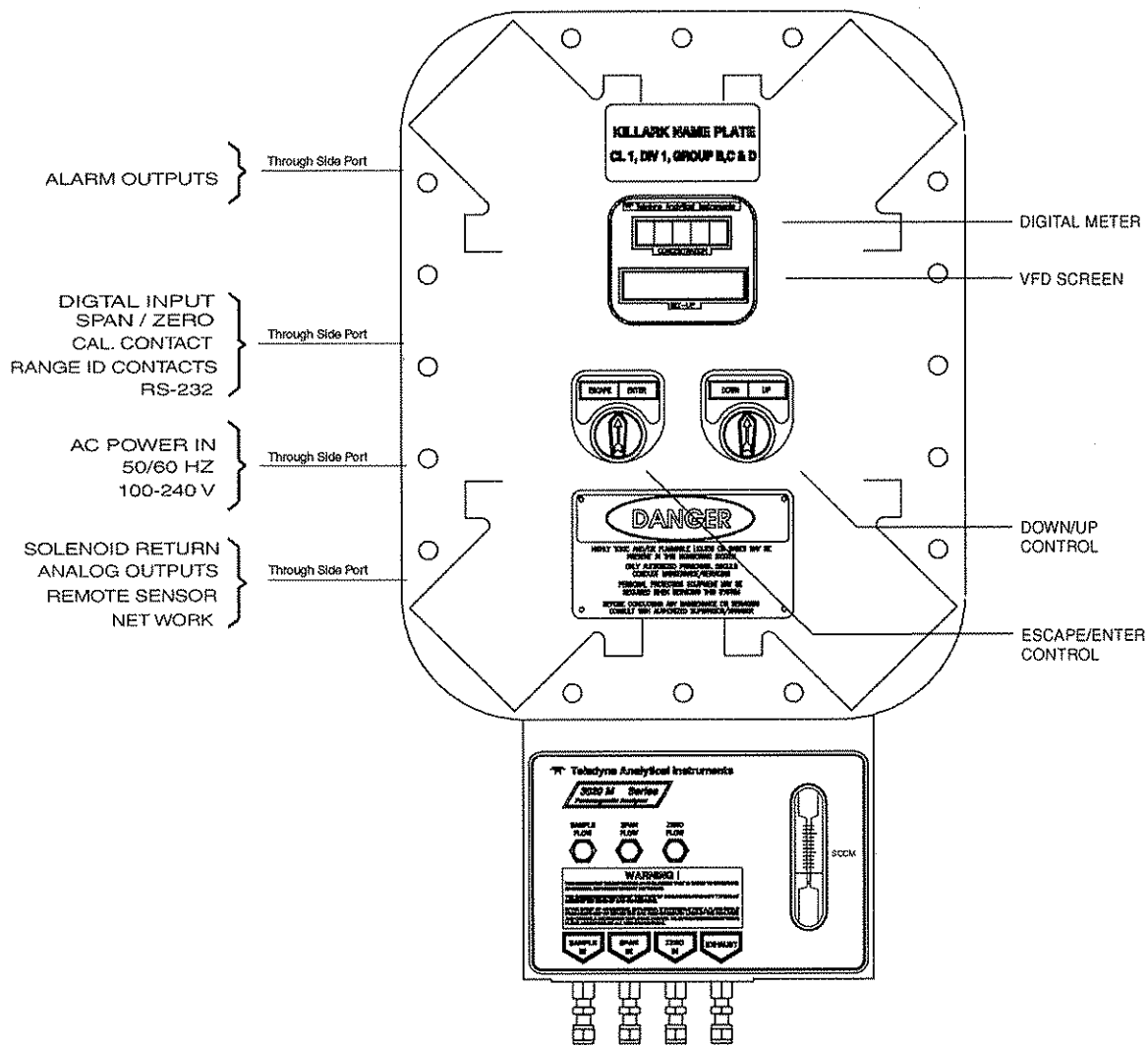

Figure 1-1: Model 3020M Controls, Indicators, and Connectors

### 1.5.1 UP/DOWN Switch

**Functions:** The UP/DOWN switch is used to select the function to be performed. Choose UP or DOWN to scroll through the following list of twelve functions:

- **Auto-Cal** Set up an automatic calibration sequence.
- **PWD** Install a password to protect your analyzer setup.
- **Logout** Locks Setup Mode.
- **Version** Displays model and version of analyzer.
- **Self-Test** Runs internal diagnostic program, displays results.
- **Span** Span calibrate the analyzer.
- **Zero** Zero calibrate the analyzer.
- **Alarms** Set the alarm setpoints and attributes.
- **Range** Set up the 3 user definable ranges for the instrument.
- **Contrast** Adjust LCD contrast. **Contrast Function is *DISABLED*** (Refer to Section 1.6)
- **Standby** Leave analyzer powered, but no outputs or displays.

**WARNING:** THE POWER CABLE MUST BE DISCONNECTED TO FULLY REMOVE POWER FROM THE INSTRUMENT.



**CAUTION:** VOLTAGE MAY BE PRESENT ON ALARM CONTACTS WHEN LINE POWER IS DISCONNECTED.

**Subfunctions:** Once a Function is entered, the UP/DOWN switch is used to select between any subfunctions displayed on the VFD screen.

**Parameter values:** When modifiable values are displayed on the VFD, the UP/DOWN switch can be used to increment or decrement the values.

### 1.5.2 ESCAPE/ENTER Switch

**Data Entry:** The ESCAPE/ENTER switch is used to input data, from the alphanumeric VFD screen into the instrument:

- **Escape** Moves VFD display back to the previous screen in a series. If none remains, returns to the *Analyze* screen.  
With subfunction selected, moves VFD back through items on screen, to first item, then moves VFD to previous display.
- **Enter** With a Subfunction Selected: Moves VFD on to the next screen in a series. If none remains, returns to the *Analyze* screen.

With a Value Selected: Enters the value into the analyzer as data. Advances VFD to next operation.

(See Chapter 4 for details.)

### 1.5.3 Displays

**Digital Meter Display:** The meter display is a LED device that produces large, bright, 7-segment numbers that are legible in any lighting. It produces a continuous readout from 0-100 %. It is accurate across all analysis ranges without the discontinuity inherent in analog range switching.

**Alphanumeric Interface Screen:** The backlit VFD screen is an easy-to-use interface from operator to analyzer. It displays values, options, and messages that give the operator immediate feedback.

**Flowmeter:** Monitors the flow of gas past the sensor. Readout is 100 to 1000 standard cc per minute (cc/min x 100) valid for air or nitrogen.

## 1.6 Recognizing Difference Between LCD & VFD

LCD has *GREEN* background with *BLACK* characters. VFD has *DARK* background with *GREEN* characters. In the case of VFD - *NO CONTRAST ADJUSTMENT IS NEEDED*.

## 1.7 Equipment Interface

### 1.7.1 Electrical Connector Panel

The electrical connector panel, shown in Figure 1-2, contains the electrical connections for external inlets and outlets. The connectors are described briefly here and in detail in the *Installation* chapter of this manual.



**CAUTION:** *The power cable must be disconnected to fully remove power from the instrument.*

**CAUTION:** *VOLTAGE MAY BE PRESENT ON ALARM CONTACTS WHEN LINE POWER IS DISCONNECTED.*

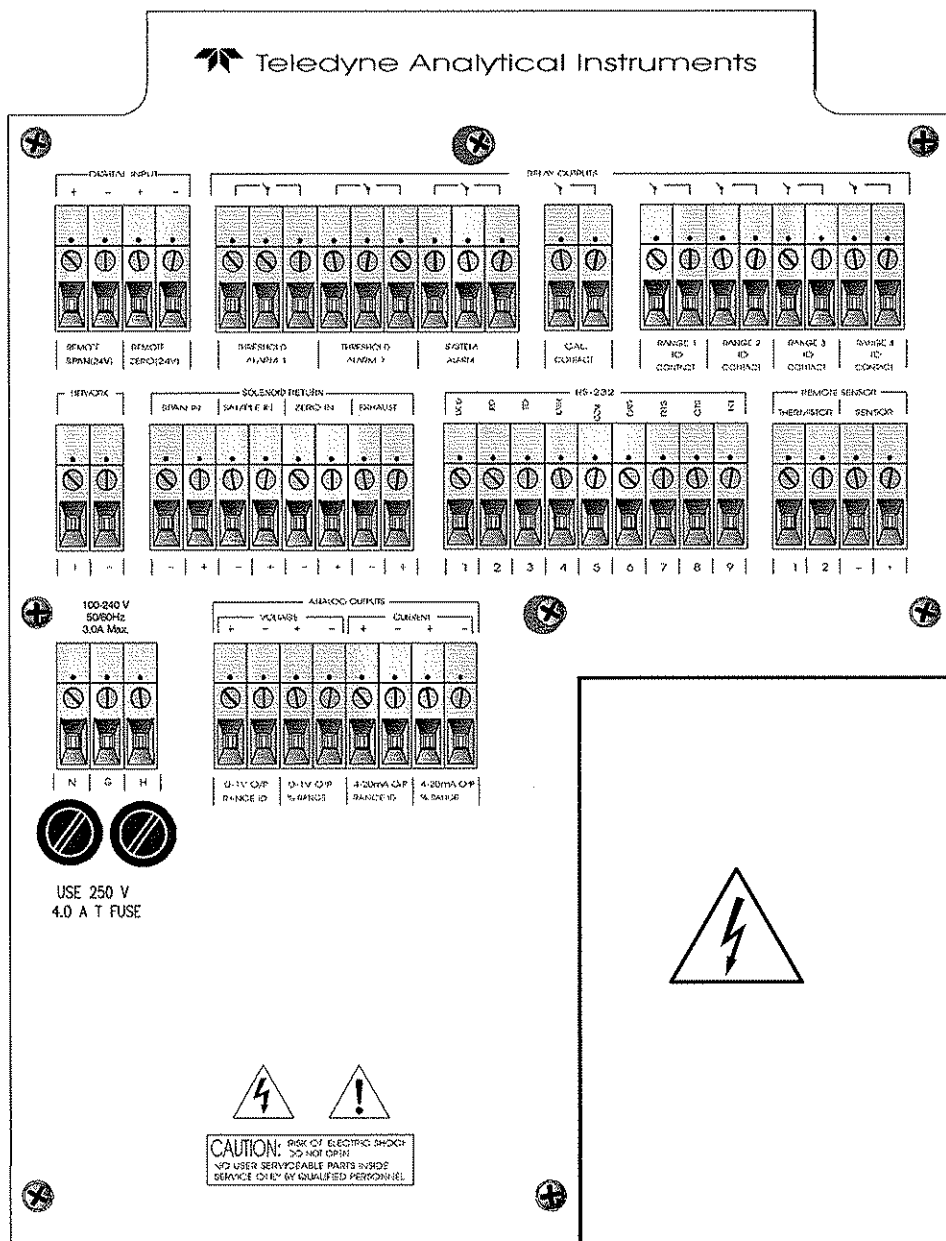

Figure 1-2: Electrical Connector Panel

**Electrical Connections:** The electrical connections on the electrical connector panel are described briefly here, and in more detail in chapter 3 *Installation*.

- **Power Connection** 100-240 VAC, 50 or 60 Hz.
- **Analog Outputs** 0-1 VDC concentration plus 0-1 V dc range ID and, isolated 4-20 mA DC plus 4-20 mADC range ID.
- **Alarm Connections** 2 concentration alarms and 1 system alarm.
- **RS-232 Port** Serial digital concentration signal output and control input.
- **Remote Valves** Used for controlling external solenoid valves, if desired.
- **Remote Span/Zero** Digital inputs allow external control of analyzer calibration.
- **Calibration Contact** To notify external equipment that instrument is being calibrated and readings are not monitoring sample.
- **Range ID Contacts** Four separate, dedicated, range relay contacts. Low, Medium, High, Cal.
- **Network I/O** Serial digital communications for local network access. For future expansion. Not implemented at this printing.

### 1.7.2 Gas Connector Panel

The gas connector panel, shown in Figure 1-3, contains the gas connections for external inlets and outlets. Those that are optional are shown shaded in the figure. The connectors are described briefly here and in detail in the *Installation* chapter of this manual.

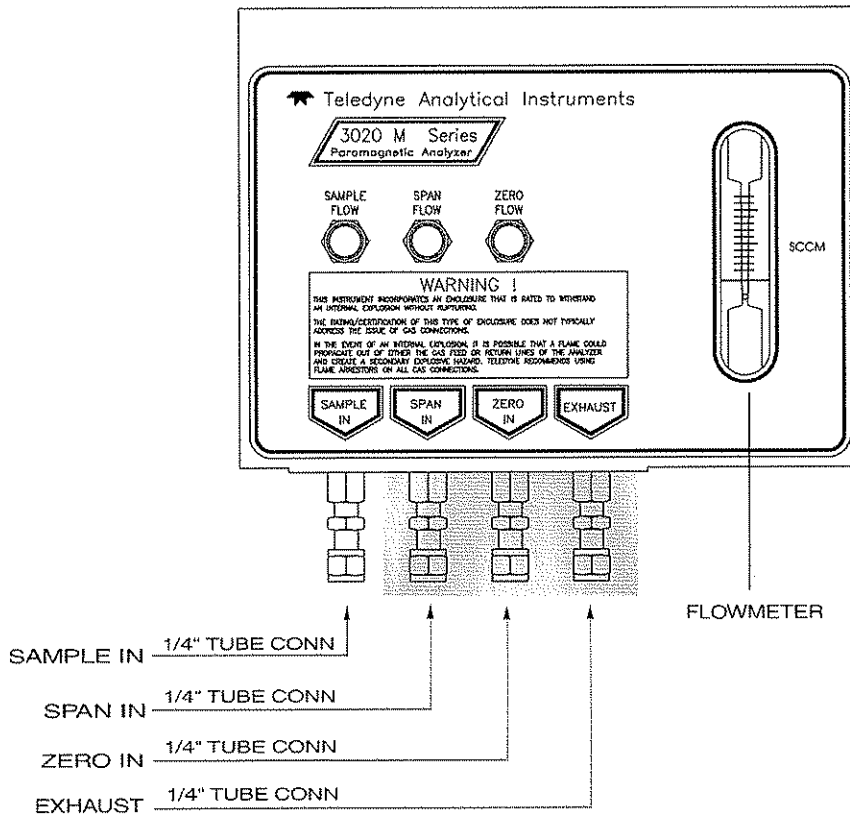

Figure 1-3: Model 3020M Gas Connector Panel

- **Gas Sample Inlet and Outlet** One inlet and one exhaust out.

**Optional:**

- **Calibration Gas Ports** Separate fittings for zero, span and sample gas input, plus internal valves for automatically switching the gases in sync with the 3020M electronics.

**Note:** If you require highly accurate Auto-Cal timing, use external Auto-Cal control where possible. The internal clock in the Model 3020M is accurate to 2-3 %. Accordingly, internally scheduled calibrations can vary 2-3 % per day.

## **Operational Theory**

---

### **2.1 Introduction**

The analyzer is composed of three subsystems:

1. Paramagnetic Sensor
2. Sample System
3. Electronic Signal Processing, Display and Control

The sample system is designed to accept the sample gas and transport it through the analyzer without contaminating or altering the sample prior to analysis. The Paramagnetic Sensor is an electromechanical device that translates the amount of oxygen present in the sample into an electrical signal. The electronic signal processing, display and control subsystem simplifies operation of the analyzer and accurately processes the sampled data. The microprocessor controls all signal processing, input/output and display functions for the analyzer.

### **2.2 Precise Paramagnetic Sensor**

#### **2.2.1 Principles of Operation**

The heart of the 3020M is a paramagnetic type oxygen sensor that is maintenance free and has a long lifetime. Oxygen has a very high magnetic susceptibility compared to other gases and thus displays a particularly paramagnetic behavior. A small glass dumbbell filled with nitrogen and rotating on a taut platinum wire is suspended in an inhomogeneous magnetic field. This glass dumbbell is diamagnetic and tends to rotate out of the magnetic field. The strength of the resulting torque determined by an susceptibility of the sample gas. This torque is compensated for by a counter torque induced by an electrically charged platinum coil on the dumbbell. The zero position of the dumbbell is controlled by means of an optical system consisting of a light source, a mirror at the dumbbell axis and a pair of detectors. The difference between the compensating currents required to bring the dumb-



bell to the zero position in the presence of zero gas (i.e. no O<sub>2</sub> present) or of sample gas is proportional to the partial pressure of oxygen in the sample gas.

The sensor enclosure is temperature controlled to 55 degrees centigrade to insure that the magnetic susceptibility of oxygen in the sample is not affected by the ambient temperature. The measuring cell has a measuring volume of approximately 3 cm<sup>3</sup>

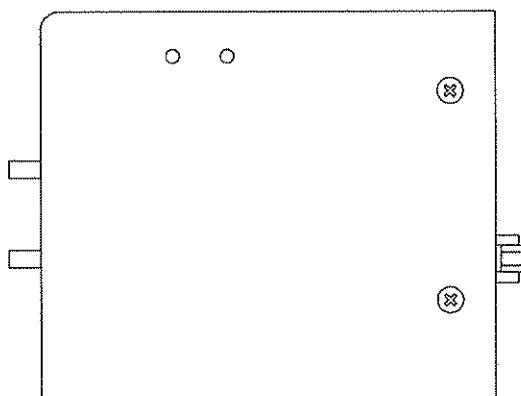

Sensor  
(side view shown)

The Paramagnetic sensor enclosure holds not only the sensing elements, but the temperature controller electronics, heating elements, sensor electronics, and preamplifier. The Electronics and heating elements require a separate power source, from the rest of the 3020M capable of delivering 1.5 amps approximately at 24 volts dc. The output of the sensor is roughly calibrated to be 0 to 1 volt DC for the the range of 0 to 100 % O<sub>2</sub>. The true calibration of the sensor is carried out by the microprocessor as described later in chapter 4. The electrical interconnections to the sensor are done through a 15 pin D connector. Some signals from the sensor are not connected. They are only useful for troubleshooting, by trained personnel, as test points.

*Sensor  
(rear view shown)*

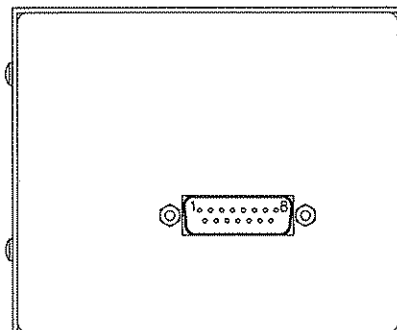

Pin out:

1	-15Vdc test pin (Not connected)
2	+15Vdc test pin (Not connected)
3	Measuring ground
4	Not used
5	Preamplifier output ~0- 1 Vdc
6	Not used
7	24 Vdc return, power ground
8	Collector of transistor switching heating element (Not connected)
9	Fault signal: <0 Vdc= OK, >4.6 Vdc = Fault (Not connected)
10	Not used
11	Negative reference voltage (Not connected)
12	Positive reference voltage (Not connected)
13	Nominal temperature voltage signal (Not connected)
14	Actual temperature voltage signal (Not connected)
15	+24 Vdc power.

## 2.3 Cross Interference

As mentioned previously, the selectivity of the measuring system is based on the extraordinarily high magnetic susceptibility of Oxygen compared to other gases. In most cases the presence of other gases can be ignored but significant errors can occur when the sensor is calibrated with a mixture of oxygen and nitrogen and the sample gas consists mainly of other gases with considerable magnetic susceptibility. In this case, the reading shows a measured value even if the sample gas contains no Oxygen. It is actually displaying the cross sensitivity to another gas.

The following table shows the cross sensitivity of some gases when changing from pure nitrogen to 100% of one of the gases listed.

Gas	Cross Sensitivity in vol. %	Gas	Cross Sensitivity in vol. %
Acetylene C <sub>2</sub> H <sub>2</sub>	-0.24	Hydrogen chloride HCl	-0.30
Allene C <sub>3</sub> H <sub>4</sub>	-0.44	Hydrogen fluoride HF	+0.10
Ammonia NH <sub>3</sub>	-0.26	Hydrogen iodide HI	-1.10
Argon Ar	-0.22	Hydrogen sulphide H <sub>2</sub> S	-0.39
Bromine Br <sub>2</sub>	-1.30	Iodine I	-2.40
1.2 Butadiene C <sub>4</sub> H <sub>6</sub>	-0.49	Isobutane C <sub>4</sub> H <sub>10</sub>	-1.11
1.3 Butadiene C <sub>4</sub> H <sub>6</sub>	-0.49	Isopentane C <sub>5</sub> H <sub>12</sub>	-1.49
n-Butane C <sub>4</sub> H <sub>10</sub>	-1.11	Krypton Kr	-0.51
I-Butane C <sub>4</sub> H <sub>8</sub>	-0.85	Laughing gas N <sub>2</sub> O	-0.20
cis 2-Butane C <sub>4</sub> H <sub>8</sub>	-0.89	Methane CH <sub>4</sub>	-0.20
trans 2-Butane C <sub>4</sub> H <sub>8</sub>	-0.92	Neon Ne	+0.13
Carbon dioxide CO <sub>2</sub>	-0.27	Neopentane C <sub>5</sub> H <sub>12</sub>	-1.49
Carbon monoxide CO	+0.06	Nitric acid HNO <sub>3</sub>	+0.43
Chlorine Cl <sub>2</sub>	-0.77	Nitrogen dioxide NO <sub>2</sub>	+28.00
Cyclo hexane C <sub>6</sub> H <sub>12</sub>	-1.56	Nitrous oxide NO	+40.00
Ethane C <sub>2</sub> H <sub>6</sub>	-0.43	n-Octane C <sub>8</sub> H <sub>18</sub>	-2.50
Ethylene C <sub>2</sub> H <sub>4</sub>	-0.26	n-Pentane C <sub>5</sub> H <sub>12</sub>	-1.45
Helium He	+0.30	Propane C <sub>3</sub> H <sub>8</sub>	-0.86
n-Heptane C <sub>7</sub> H <sub>16</sub>	-2.10	Propylene C <sub>3</sub> H <sub>6</sub>	-0.55
n-Hexane C <sub>6</sub> H <sub>14</sub>	-1.70	Vinyl chloride	-0.63
Hydrogen H <sub>2</sub>	+0.24	Water H <sub>2</sub> O	-0.02
Hydrogen bromide HBr	-0.61	Xenon Xe	-0.95

With gas mixtures the components are weighted according to their proportional volumes.

The cross interference with a gas mixture can be determined in advance if the concentration of the individual background gases is known.

Example:

Cross sensitivity calculation for a gas mixture:

The gas to be measured consists of 10 % CO<sub>2</sub>, 40 % of N<sub>2</sub>, and 50% of Ar.

$$\text{CO}_2: -0.27 \times 10\% = -0.027$$

$$\text{Ar: } -0.22 \times 50\% = -0.11$$

$$\text{TOTAL CROSS INTERFERENCE } -0.137$$

Calculation of the zero value:

$$(0\% \text{ O}_2) - (\text{Cross Interference Value}) = \text{Zero Point Value}$$

$$0\% - (-0.137) = +0.137\% \text{ O}_2$$

## 2.4 Sample System

The sample system delivers gases to the sensor from the analyzer gas panel inlets. Depending on the mode of operation either sample or calibration gas is delivered.

The Model 3020M sample system is designed and fabricated to ensure that the oxygen concentration of the gas is not altered as it travels through the sample system. The sample encounters almost no dead space. This minimizes residual gas pockets that can interfere with low percent range analysis.

The sample system for the standard instrument incorporates ¼ inch tube fittings for sample inlet and outlet connections at the rear panel. For metric system installations, 6 mm adapters are supplied with each instrument to be used if needed. The sample or calibration gas flowing through the system is monitored by a flowmeter downstream from the sensor.

The gases delivered to the instrument should be at constant pressures and flow rates and must exit freely into the ambient atmosphere. The Span, Zero and Sample gases should be delivered at constant pressures of about 10 psig (Range 5-20). The flow rate must be maintained at about 700 cc/minute (Range 600-1000) and must exit freely into atmospheric pressure.

Figure 2-4 is the flow diagram for the sampling system. In the standard instrument, calibration gases (zero and span) can be connected directly to the Sample In port by teeing to the port with appropriate valves. The shaded portions of the diagram show the components added when the -C and/or -F options are ordered. The solenoid valves, when supplied, are installed inside the 3020M enclosure and are regulated by the instrument's internal electronics. The flame arrestors, when supplied, are installed in the Gas Connector Panel.

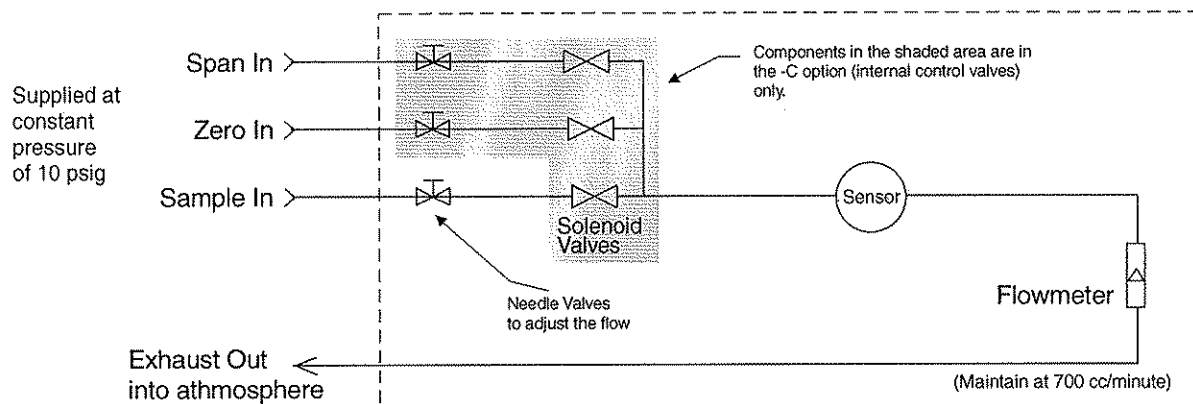

Figure 2-4: Flow Diagram

## 2.5 Electronics and Signal Processing

The Model 3020M Percent Oxygen Analyzer uses an 8031 microcontroller with 32 kB of RAM and 128 kB of ROM to control all signal processing, input/output, and display functions for the analyzer. System power is supplied from a universal power supply module designed to be compatible with most international power sources. See chapter 5 *Maintenance* for the location of the power supply and the main electronic PC boards. The Paramagnetic Sensor has its own dedicated universal 24V power supply that feeds the sensors internal heater and electronics.

The signal processing electronics including the microprocessor, analog to digital, and digital to analog converters are located on the main PCB, on the front door (see figure 5-1). The preamplifier board is mounted on top of the motherboard. These boards are accessible by opening the front door of the explosion proof enclosure. Figure 2-5 is a block diagram of the Analyzer electronics.

In the presence of oxygen the chamber is rotated in the magnetic field, but the cell generates a current to countertorque the oxygen action. This current is converted to a voltage, which is preamplified in the sensor internal electronics.

The preamplified signal (0-1 Volt) is fed to the 3020M amplifier for minor processing.

The digital concentration signal along with input from the control panel is processed by the microprocessor, and appropriate control signals are directed to the display, alarms and communications port. The same digital information is also sent to a 12 bit digital to analog converter that produces the 4-20 mA dc and the 0-1 V dc analog concentration signal outputs, and the analog range ID outputs.

Signals from the power supply are also monitored, and through the microprocessor, the system failure alarm is activated if a malfunction is detected.

## 2.6 Temperature Control

For accurate analysis the sensor temperature is controlled internally at 55°C.

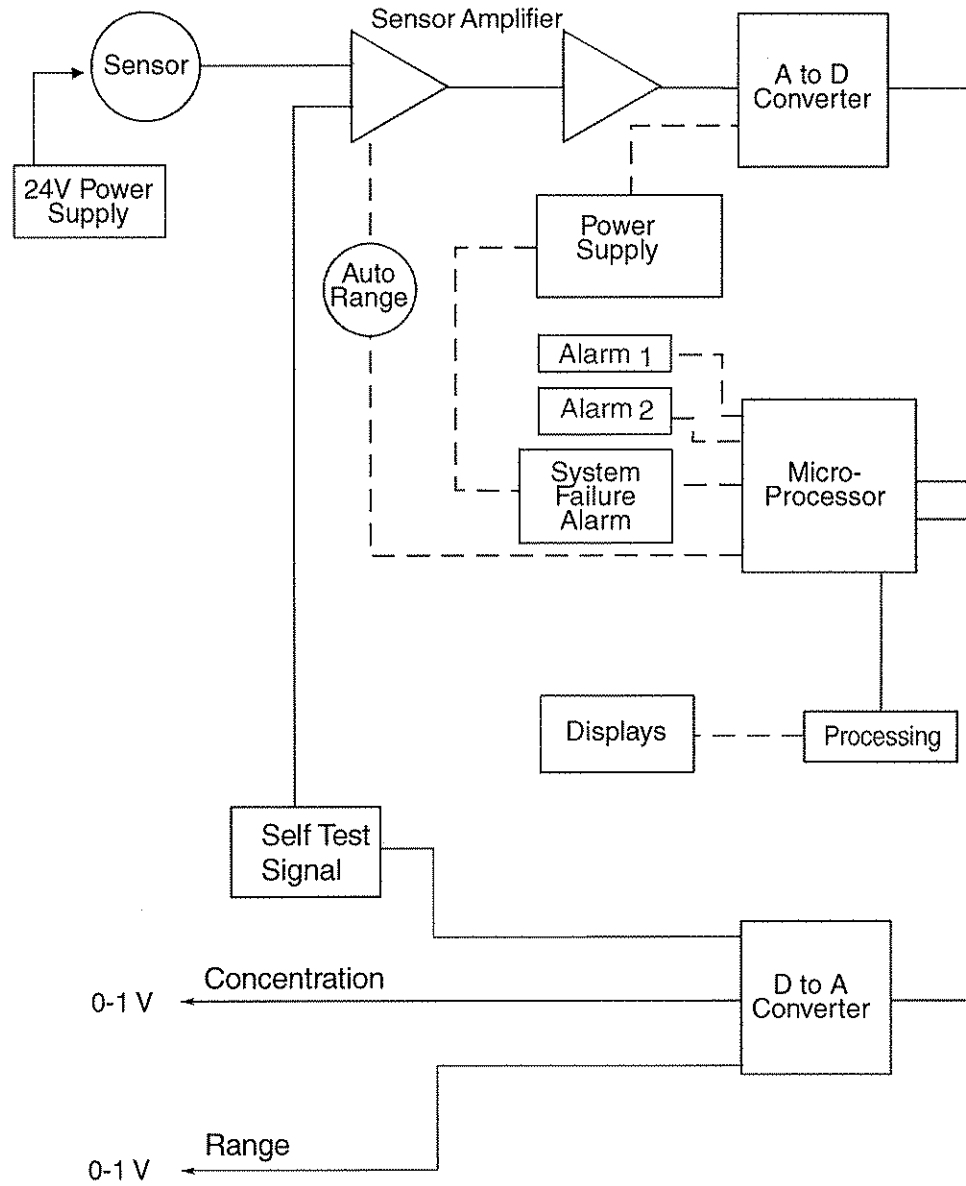

Figure 2-5: Block Diagram of the Model 3020M Electronics



---

## Installation

---

Installation of the Model 3020M Analyzer includes:

1. Unpacking
2. Mounting
3. Gas connections
4. Electrical connections
5. Testing the system.

### 3.1 Unpacking the Analyzer

The analyzer is shipped with all the materials you need to install and prepare the system for operation. Carefully unpack the analyzer and inspect it for damage. Immediately report any damage to the shipping agent.

### 3.2 Mounting the Analyzer

The Model 3020M is designed for bulkhead mounting in hazardous environments. There are four mounting lugs—one in each corner of the enclosure. The outline drawing, at the back of this manual, gives the mounting hole size and spacing. The drawing also contains the overall dimensions. Do not forget to allow an extra 1<sup>3</sup>/<sub>8</sub>" for the hinges.

The 3020M ***MUST be mounted and operated in the upright position*** as shown in figure 3-1. The paramagnetic sensor is orientation sensitive and will not work correctly if operated horizontally (on its back or side).

Be sure to allow enough space in front of the enclosure to swing the door open—a 16 1/4" radius, as shown in Figure 3-2.

All electrical connections are made via cables which enter the explosion-proof housing through ports in its side. No conduit fittings are supplied. The installer must provide two 3/4" NPT and two 1" NPT adapters and the appropriate sealing conduit.



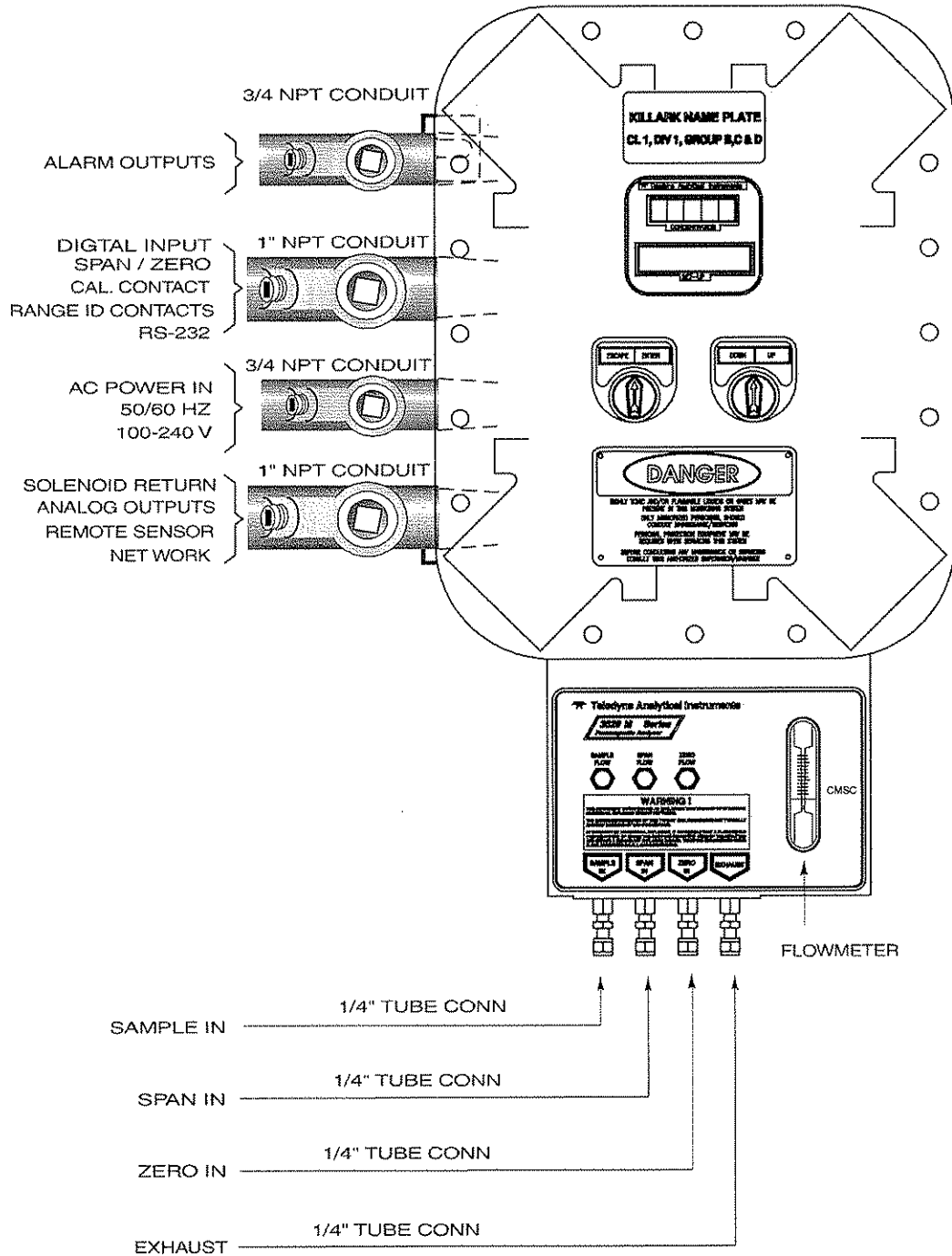

Figure 3-1: Front View of the Model 3020M (Simplified)

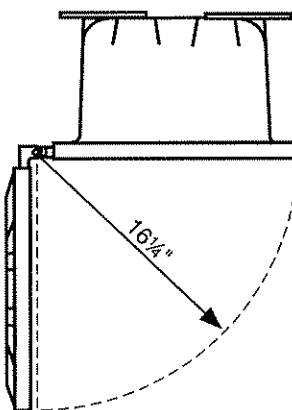

Figure 3-2: Required Front Door Clearance

### 3.3 Electrical Connections



Figure 3-3 shows the Model 3020M Electrical Connector Panel. There are terminal blocks for connecting power, communications, and both digital and analog concentration outputs.

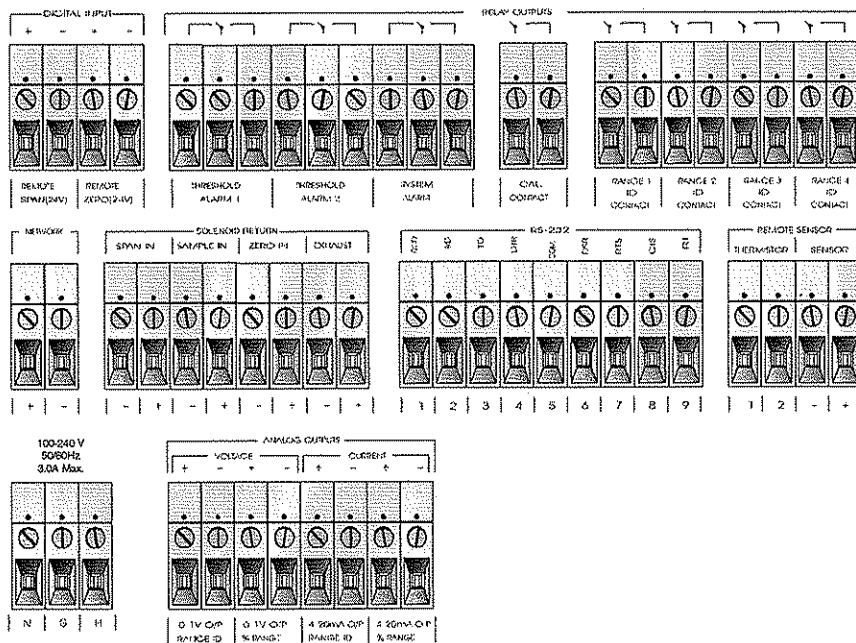

Figure 3-3: Electrical Connector Panel

For safe connections, ensure that no uninsulated wire extends outside of the connectors they are attached to. Stripped wire ends must insert completely into terminal blocks. No uninsulated wiring should be able to come in contact with fingers, tools or clothing during normal operation.

### 3.3.1 Primary Input Power

The universal power supply requires a 100-240 VAC, 50 or 60 Hz power source. See Figure 3-4 for detailed connections.

**DANGER:** *Power is applied to the instrument's circuitry as long as the instrument is connected to the power source. The Standby function switches power on or off to the displays and outputs only.*

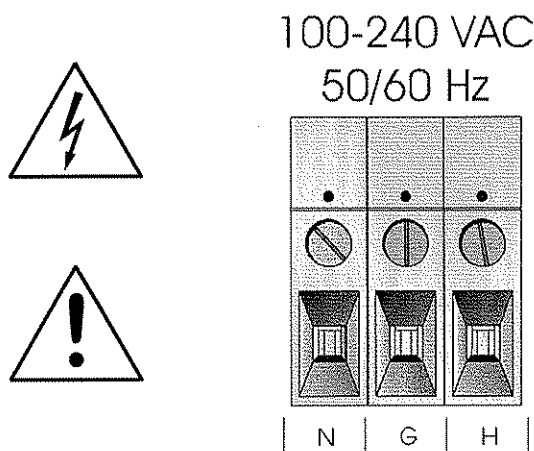

Figure 3-4: Primary Input Power Connections

### 3.3.2 Fuse Installation

The fuse holders accept 5 x 20 mm, 4.0 A, T type (slow blow) fuses. Fuses are not installed at the factory. Be sure to install the proper fuse as part of installation. (See *Fuse Replacement* in chapter 5, *maintenance*.)

### 3.3.3 Analog Outputs

There are eight DC output signal connectors on the ANALOG OUTPUTS connector block. There are two connectors per output with the polarity noted. See Figure 3-5.

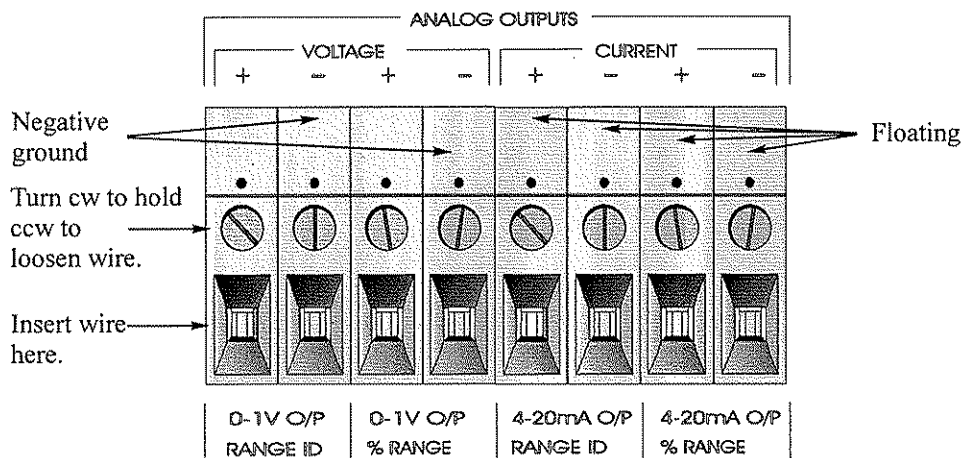

Figure 3-5: Analog Output Connections

The outputs are:

0–1 VDC % of Range: Voltage rises linearly with increasing oxygen, from 0 V at 0 % to 1 V at full scale. (Full scale = 100% of programmable range.)

0–1 VDC Range ID: 0.25 V = Low Range, 0.5 V = Medium Range, 0.75 V = High Range, 1 V = Air Cal Range.

4–20 mADC % Range: (-M Option) Current increases linearly with increasing oxygen, from 4 mA at 0 % to 20 mA at full scale. (Full scale = 100% of programmable range.)

4–20 mADC Range ID: 8 mA = Low Range, 12 mA = Medium Range, 16 mA = High Range, 20 mA = Air Cal Range.

### Examples:

The analog output signal has a voltage which depends on the oxygen concentration AND the currently activated analysis range. To relate the signal output to the actual concentration, it is necessary to know what range the instrument is currently on, especially when the analyzer is in the autoranging mode.

The signal output for concentration is linear over the currently selected analysis range. For example, if the analyzer is set on a range that was defined as 0–10 % O<sub>2</sub>, then the output would be as shown in Table 3-1.

**Table 3-1: Analog Concentration Output—Example**

% O <sub>2</sub>	Voltage Signal Output (V dc)	Current Signal Output (mA dc)
0	0.0	4.0
1	0.1	5.6
2	0.2	7.2
3	0.3	8.8
4	0.4	10.4
5	0.5	12.0
6	0.6	13.6
7	0.7	15.2
8	0.8	16.8
9	0.9	18.4
10	1.0	20.0

To provide an indication of the range, a second pair of analog output terminals are used. They generate a steady preset voltage (or current when using the current outputs) to represent a particular range. Table 3-2 gives the range ID output for each analysis range.

**Table 3-2: Analog Range ID Output—Example**

Range	Voltage (V)	Current (mA)
LO	0.25	8
MED	0.50	12
HI	0.75	16
0-25% Non Programmable	1.00	20

**NOTE:** Impedance across 4-20mA output should not exceed 1000 ohms. Note polarity of terminals when wiring to the analog outputs. Do not short 0-1VDC output for long period of time, or damage may occur to analyzer.

**CAUTION:** Voltage may be present on alarm contacts when line power is disconnected.



### 3.3.4 Alarm Relays

There are three alarm-circuit connectors on the alarm relays block (under RELAY OUTPUTS) for making connections to internal alarm relay contacts. Each provides a set of Form C contacts for each type of alarm. Each has both normally open and normally closed contact connections. The contact connections are indicated by diagrams on the connector panel. They are capable of switching up to 3 amperes at 250 VAC into a resistive load. See Figure 3-6.

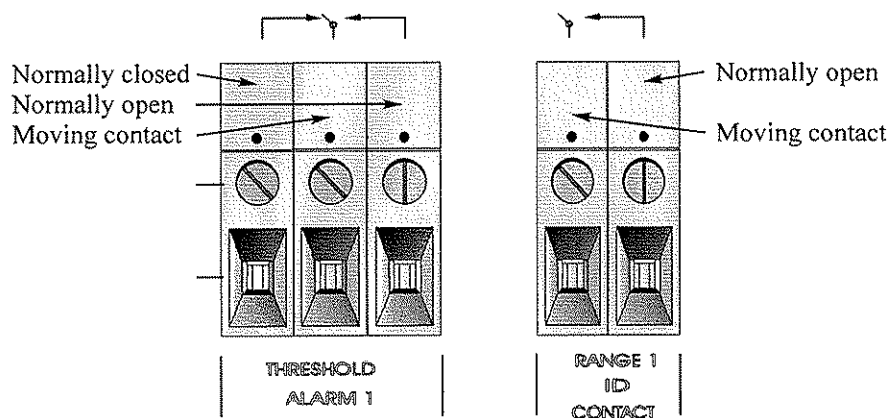

Figure 3-6: Types of Relay Contacts

The connectors are:

- Threshold Alarm 1:
- Can be configured as high (actuates when concentration is above threshold), or low (actuates when concentration is below threshold).
  - Can be configured as failsafe or non-failsafe.
  - Can be configured as latching or non-latching.
  - Can be configured out (defeated).
- Threshold Alarm 2:
- Can be configured as high (actuates when concentration is above threshold), or low (actuates when concentration is below threshold).
  - Can be configured as failsafe or non-failsafe.
  - Can be configured as latching or non-latching.
  - Can be configured out (defeated).
- System Alarm:
- Actuates when DC power supplied to circuits is unacceptable in one or more parameters. Permanently configured as failsafe and latching. Cannot be defeated. Actuates if self test fails.
- To reset a System Alarm during installation, disconnect power to the instrument and then reconnect it.

Further detail can be found in chapter 4, section 4-10.

**CAUTION:** *Power may be present on this contacts even when power to analyzer has been removed since this contacts are wired by the customer.*



### 3.3.5 Digital Remote Cal Inputs

**Remote Zero and Span Inputs:** The REMOTE SPAN and REMOTE ZERO inputs are on the DIGITAL INPUT terminal block. They accept 0 V (OFF) or 24 V dc (ON) for remote control of calibration. (See *Remote Calibration Protocol* below.)

**ZERO:** Floating input. 5 to 24 V input across the + and – terminals puts the analyzer into the *Zero* mode. Either side may be grounded at the source of the signal. 0 to 1 volt across the terminals allows *Zero* mode to terminate when done. A synchronous signal must open and close the external zero valve appropriately. See 3.3.9 *Remote Sensor and Solenoid Valves*. (With the –C option, the internal valves automatically operate synchronously.)

**SPAN:** Floating input. 5 to 24 V input across the + and – terminals puts the analyzer into the *Span* mode. Either side may be grounded at the source of the signal. 0 to 1 volt across the terminals allows *Span* mode to terminate when done. A synchronous signal must open and close the external span valve appropriately. See 3.3.9 *Remote Sensor and Solenoid Valves*. (With the –C option, the internal valves automatically operate synchronously.)

**Cal Contact:** This relay contact is closed while analyzer is spanning and/or zeroing. (See *Remote Calibration Protocol* below.)

**Remote Calibration Protocol:** To properly time the Digital Remote Cal Inputs to the Model 3020M Analyzer, the customer's controller must monitor the CAL CONTACT relay.

When the contact is OPEN, the analyzer is analyzing, the Remote Cal Inputs are being polled, and a zero or span command can be sent.

When the contact is CLOSED, the analyzer is already calibrating. It will ignore your request to calibrate, and it will not remember that request.

Once a zero or span command is sent, and acknowledged (contact closes), release it. If the command is continued until after the zero or span is complete, the calibration will repeat and the Cal Relay Contact (CRC) will close again.

For example:

- 1) Test the CRC. When the CRC is open, Send a zero command until the CRC closes (The CRC will quickly close.)
- 2) When the CRC closes, remove the zero command.
- 3) When CRC opens again, send a span command until the CRC closes. (The CRC will quickly close.)
- 4) When the CRC closes, remove the span command.

When CRC opens again, zero and span are done, and the sample is being analyzed.

**Note:** The remote probe connections (paragraph 3.3.9) provides signals to ensure that the zero and span gas valves will be controlled synchronously. If you have the -C Internal valve option—which includes additional zero and span gas inputs—the 3020M automatically regulates the zero, span and sample gas flow.

### 3.3.6 Range ID Relays

There are four dedicated RANGE ID CONTACT relays. The first three ranges are assigned to relays in ascending order—Low range is assigned to RANGE 1 ID, Medium range is assigned to RANGE 2 ID, and High range is assigned to RANGE 3 ID. RANGE 4 ID is reserved for the Air Cal Range (25%).

### 3.3.7 Network I/O

A serial digital input/output for local network protocol. At this printing, this port is not yet functional. It is to be used in future versions of the instrument.

### 3.3.8 RS-232 Port

The digital signal output is a standard RS-232 serial communications port used to connect the analyzer to a computer, terminal, or other digital device. The pinouts are listed in Table 3-3.

**Table 3-3: RS-232 Signals**

RS-232 Sig	RS-232 Pin	Purpose
DCD	1	Data Carrier Detect
RD	2	Received Data
TD	3	Transmitted Data



DTR	4	Data Terminal Ready
COM	5	Common
DSR	6	Data Set Ready
RTS	7	Request to Send
CTS	8	Clear to Send
RI	9	Ring Indicator

The data sent is status information, in digital form, updated every two seconds. Status is reported in the following order:

- The concentration in percent
- The range in use (HI, MED, LO)
- The span of the range (0-100 %, etc)
- Which alarms—if any—are disabled (AL-x DISABLED)
- Which alarms—if any—are tripped (AL-x ON).

Each status output is followed by a carriage return and line feed.

Four input functions using RS-232 have been implemented to date. They are described in Table 3-4.

**Table 3-4: Commands via RS-232 Input**

Command	Description
as<enter>	Immediately starts an autospan.
az<enter>	Immediately starts an autozero.
st<enter>	Toggling input. Stops/Starts any status message output from the RS-232, until st<enter> is sent again.

The RS-232 protocol allows some flexibility in its implementation. Table 3-5 lists certain RS-232 values that are required by the 3020M implementation.

**Table 3-5: Required RS-232 Options**

Parameter	Setting
Baud	2400
Byte	8 bits
Parity	none
Stop Bits	1
Message Interval	2 seconds

### 3.3.9 Remote Sensor and Solenoid Valves

The 3020M is a single-chassis instrument, which has its own sensor and, in the -C option, its own gas-control solenoid valves. The REMOTE SENSOR connector is not used, and the SOLENOID RETURN connectors are used (without the -C option) to synchronize external gas control valves. See Figure 3-7.

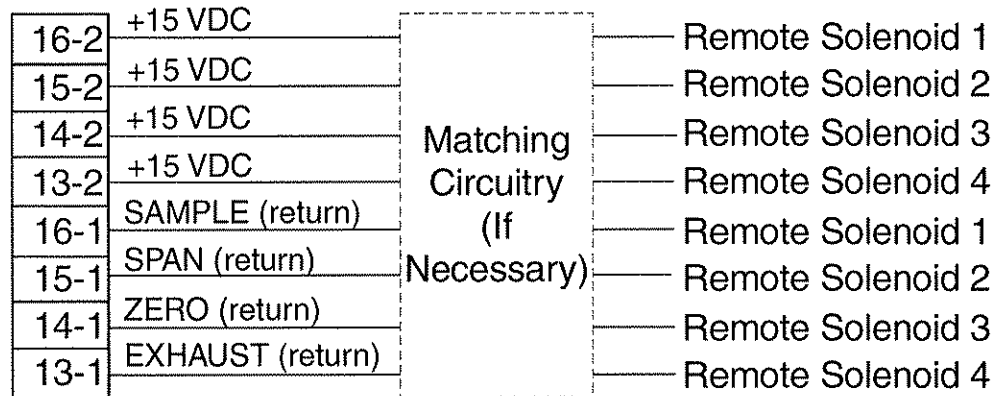

Figure 3-7: Remote Solenoid Return Connector Pinouts

The voltage from these outputs is nominally 0 V for the OFF and 15 V dc for the ON conditions. The maximum combined current that can be pulled from these output lines is 100 mA. (If two lines are ON at the same time, each must be limited to 50 mA, etc.) If more current and/or a different voltage is required, use a relay, power amplifier, or other matching circuitry to provide the actual driving current.

In addition, each individual line has a series FET with a nominal ON resistance of 5 ohms (9 ohms worst case). This could limit the obtainable voltage, depending on the load impedance applied. See Figure 3-8.

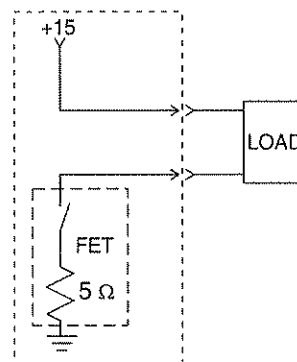

Figure 3-8: FET Series Resistance

### 3.4 Gas Connections

Figure 3-9 is an illustration of the Gas Connector Panel. Optional gas connections are shown in shaded blocks.

The unit is manufactured with 1/4 inch tube fittings only. Adapters must be used for metric tubing. (At least 6 mm is recommended.)

For a safe connection:

1. Insert the tube into the tube fitting, and finger-tighten the nut until the tubing cannot be rotated freely, by hand, in the fitting. (This may require an additional 1/8 turn beyond finger-tight.)
2. Hold the fitting body steady with a backup wrench, and with another wrench rotate the nut another 1 1/4 turns.

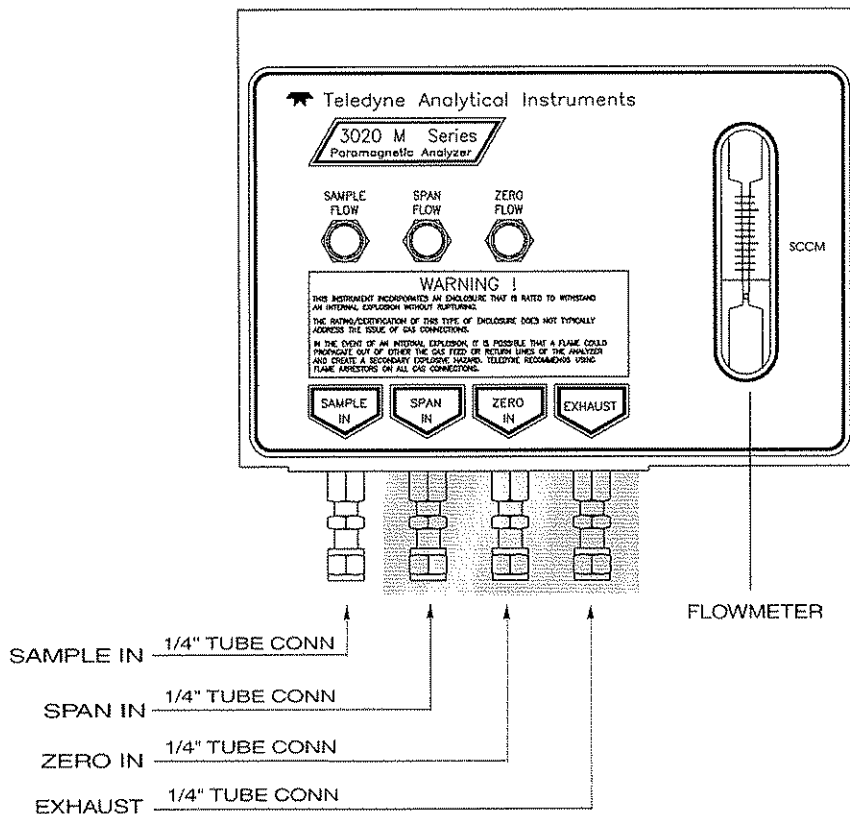

Figure 3-9: Gas Connector Panel

**SAMPLE IN:** In the standard model, gas connections are made at the SAMPLE IN and EXHAUST OUT connections. Calibration gases must be Tee'd into the Sample inlet with appropriate valves.

The gas pressure in should be regulated at about 10 psig. Pressures between 5 and 20 psig are acceptable as long as the pressure, once established, will keep the front panel flowmeter reading in an acceptable range of 700 cc/minute.

If greater flow is required for improved response time, install a bypass in the sampling system upstream of the analyzer input.

**ZERO IN and SPAN IN:** These are additional ports, included on models with the -C option, for inputting span gas and zero gas. There are electrically operated valves inside for automatic switching between sample and calibration gases. These valves are completely under control of the 3020M Electronics. They can be externally controlled only indirectly through the Remote Cal Inputs, described below.

Pressure, flow, and safety considerations are the same as prescribed for the SAMPLE IN inlet, above.

**EXHAUST OUT:** Exhaust connections must be consistent with the hazard level of the constituent gases. Check Local, State, and Federal laws, and ensure that the exhaust stream vents to an appropriately controlled area if required.

### 3.5 Testing the System

Before plugging the instrument into the power source:

- Check the integrity and accuracy of the gas connections. Make sure there are no leaks.
- Check the integrity and accuracy of the electrical connections. Make sure there are no exposed conductors
- Check that sample pressure is between 5 and 20 psig, according to the requirements of your process, and the exhaust line is open to atmosphere.

Power up the system, and test it by performing the following operations:

1. Repeat the Self-Diagnostic Test as described in chapter 5, section 5.5.



## Operation

---

### 4.1 Introduction

Once the analyzer has been installed, it can be configured for your application. To do this you will:

- Establish and start an automatic calibration cycle, if desired. (Electrically operated valves required.)
- Define the three user selectable analysis ranges. Then choose autoranging or select a fixed range of analysis, as required.
- Calibrate the instrument.
- Set alarm setpoints, and modes of alarm operation (latching, failsafe, etc).
- Establish a security password, if desired, requiring Operator to log in.

Before you configure your 3020M these default values are in effect:

**Ranges:** LO = 0-5 %, MED = 0-25 %, HI = 0-100 %.

**Auto Ranging:** ON

**Alarm Relays:** Defeated, 10 %, HI, Not failsafe, Not latching.

**Zero:** Auto, every 0 days at 0 hours.

**Span:** Auto, at 20.9 %, every 0 days at 0 hours.

**Password:** T E T A I

### 4.2 Using the Controls

To get the proper response from these controls, turn the control toward the desired action (ESCAPE or ENTER—DOWN or UP), and then release it. Turn-and-release once for each action. For example, turn-and-release twice toward UP to move the VFD screen two selections upwards on the list of options (menu).

The item that is between arrows on the screen is the item that is currently selectable by choosing ENTER (turn-and-release toward ENTER with the ESCAPE/ENTER control).

In these instructions, to ENTER means to turn-and-release toward ENTER, and To ESCAPE means to turn-and-release towards ESCAPE. To scroll UP (or scroll DOWN) means to turn-and-release toward UP (or DOWN) as many times as necessary to reach the required menu item.

### 4.2.1 Mode/Function Selection

When the analyzer is first powered up, and has completed its initialization and self diagnostics, ESCAPE toggles the instrument between the ANALYZE screen (*Analysis Mode*) and the MAIN MENU screen (*Setup Mode*). The ANALYZE screen is the only screen of the *Analysis Mode*.

The MAIN MENU screen is the top level in a series of screens used in the *Setup Mode* to configure the analyzer for the specific application. The DOWN/UP commands scroll through the options displayed on the VFD screen. The selectable option appears between arrows. When you reach the desired option by scrolling, ENTER the selection as described below.

ESCAPE takes you back up the hierarchy of screens until you reach the MAIN MENU again. ESCAPING any further just toggles between the MAIN MENU and the ANALYZE screen.

#### 4.2.1.1 Analysis Mode

This is the normal operating mode. The analyzer monitors the oxygen content of the sample, displays the percent of oxygen, and warns of any alarm conditions. Either control switches you to *Setup Mode*. *Setup Mode* switches back to *Analysis Mode* if no controls are used for more than five seconds.

#### 4.2.1.2 Setup Mode

The MAIN MENU consists of 12 functions you can use to customize and check the operation of the analyzer. Figure 4-1 shows the functions available with the 3020M. They are listed here with brief descriptions:

- 1 AUTO-CAL: Used to define and/or start an automatic calibration sequence.
- 2 PWD: Used to establish password protection or change the existing password.
- 3 LOGOUT: Logging out prevents unauthorized tampering with the analyzer settings.

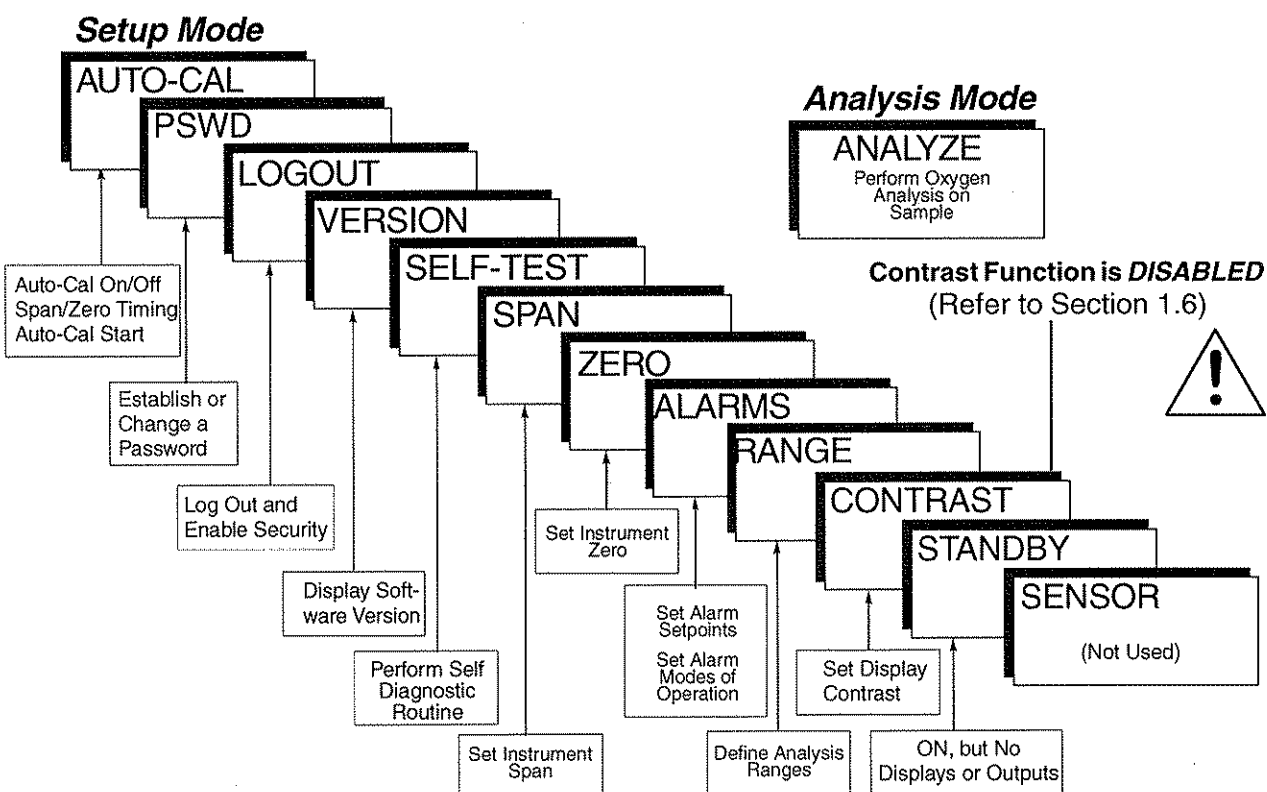

Figure 4-1: Modes and Functions

- 4 **VERSION**: Displays Manufacturer, Model, and Software version of the instrument.
- 5 **SELF-TEST**: The instrument performs a self-diagnostic routine to check the integrity of the power supply, output boards and amplifiers.
- 6 **SPAN**: Set up and/or start a span calibration.
- 7 **ZERO**: start a zero calibration.
- 8 **ALARMS**: Used to set the alarm setpoints and determine whether each alarm will be active or defeated, HI or LO acting, latching or not, and failsafe or not.
- 9 **RANGE**: Used to set up three analysis ranges that can be switched automatically with auto-ranging or used as individual fixed ranges.



- 10 STANDBY: Remove power to outputs and displays, but maintain power to internal circuitry.
- 11 SENSOR (Not Used).

Any function can be selected at any time. Just scroll through the MAIN MENU with the DOWN/UP control to the appropriate function, and ENTER it. The analyzer will immediately start that function, unless password restrictions have been assigned. (Password assignment is explained further on.)

All of these functions are described in greater detail in the procedures starting in section 4.3. The VFD screen texts used to illustrate the procedures are reproduced in a Monospaced type style.

## 4.2.2 Data Entry

### 4.2.2.1 ENTER

When the selected option is a function on the Main Menu screen, the function name appears between the arrows on the screen. You activate the function by turning the ESCAPE/ENTER control to ENTER.

When the selected option is a **function or subfunction**, ENTER moves the display to the VFD screen for that function or subfunction.

When the selected option is a **modifiable item**, the DOWN/UP control can be used to increment or decrement that modifiable item to the value or action you want. Then you ENTER the item, which also puts you into the next field to continue programming.

When the last field is entered, ENTER takes you to the next screen in the process, or if the process is completed, ENTER takes you back to the ANALYZE screen.

### 4.2.2.2 ESCAPE

A turn-and-release toward ESCAPE moves the blinking to the next field on the left. When you are on the leftmost field, another ESCAPE takes you back to the previous screen.

If you do not wish to continue a function, you can abort the session by escaping to the leftmost field, and then issuing another ESCAPE. Escaping a function takes the analyzer back to the previous screen, or to the ANALYZE Function, depending on the function escaped.

### 4.3 The AUTO-CAL Function

When proper automatic valving is connected (see chapter 3, *installation*), the Analyzer can cycle itself through a sequence of steps that automatically zero and span the instrument.

**Note:** If you require highly accurate timing of your AUTO-CAL, use external AUTO-CAL control where possible. The internal clock in the Model 3020M is accurate to 2-3 %. Accordingly, internally scheduled calibrations can vary 2-3 % per day.

To setup an AUTO-CAL cycle:

Scroll to AUTO-CAL, and ENTER. A new screen for Span/Zero set appears.

**Span OFF Nxt: 0d 0h**  
**Zero OFF Nxt: 0d 0h**

If SPAN (or ZERO) is not flashing, scroll with DOWN/UP control to SPAN (or ZERO), then ENTER. (*You won't be able to set OFF to ON if a zero interval is entered.*) A Span Every ... (or Zero Every ...) screen appears.

**Span Every 0 d**  
**Start 0 h from now**

Use DOWN/UP control to set an interval value, and ENTER. Then use DOWN/UP to set a start-time value, and ENTER.

**Span OFF Nxt: 0d 0h**  
**Zero OFF Nxt: 0d 0h**

When the Span/Zero values screen appears, use the scroll DOWN to blink the OFF/ON field of the SPAN (or ZERO) function. Use DOWN/UP to set the OFF/ON field to ON. *You can now turn these fields ON because there is a nonzero span interval defined.*

### 4.4 The PWD (Password) Function

Security can be established by choosing a 5 digit password from the standard ASCII character set. If you decide NOT to employ password security, use the default password TETAL. This password will be displayed automatically by the microprocessor. The operator just ENTERs it to be allowed total access to the instrument's features.

Once a unique password is assigned and activated, the operator MUST enter the UNIQUE password to gain access to any of the set-up functions (except to enter the **password**). However, the instrument will continue to

analyze sample gas and report on alarm conditions without entering the password.

- **Only one password can be defined.**
- After a password is assigned, the operator must **log out** to activate it. Until then, anyone can continue to operate the instrument without entering the new password.
- To defeat the security after a unique password is activated, the password must be changed back to TETAI.

**NOTE: If you use password security, it is advisable to keep a copy of the password in a separate, safe location.**

#### 4.4.1 Entering the Password

To install a new password or change a previously installed password, you must key in and enter the old password first. If the default password is in effect, issuing the ENTER command will enter the default TETAI password for you.

Scroll to PWD, and ENTER to select the password function. Either the TETAI default password or AAAAA place-holder password for an existing password will appear on screen depending on whether or not a password has been previously installed.

```
T E T A I
Enter PWD

  O R

A A A A A
Enter PWD
```

The screen prompts you to enter the current password. If you are not using password protection, ENTER to accept TETAI as the default password. If a password has been previously installed, enter the password using ENTER to scroll through the letters, and the DOWN/UP keys to change the letters to the proper password. The last ENTER enters the password.

If the password is accepted, the screen will indicate that the password restrictions have been removed and you have clearance to proceed.

```
PWD Restrictions
Removed
```

In a few seconds, if you do not ESCAPE, you will be given the opportunity to change this password or keep it and go on.

**Change Password?****<ENT>=Yes <ESC>=No**

ESCAPE to move on, or proceed as in *Changing the Password*, below.

**4.4.2 Installing or Changing the Password**

If you want to change the existing password: Proceed as above in *Entering the Password*, until you are given the opportunity to change the password:

**Change Password?****<ENT>=Yes <ESC>=No**

ENTER to change the password (to change either the default TETA1 or the previously assigned password), or ESCAPE to keep the existing password and move on.

If you choose ENTER to change the password, the password assignment screen appears.

**T E T A 1****<ENT> To Proceed**or**A A A A A****<ENT> To Proceed**

Enter the password using ENTER to scroll through the existing password letters, and DOWN/UP to change the letters to the new password. The full set of 94 characters available for password use are shown in the table below.

**Characters Available for Password Definition:**

A	B	C	D	E	F	G	H	I	J
K	L	M	N	O	P	Q	R	S	T
U	V	W	X	Y	Z	[	¥	]	^
_	`	a	b	c	d	e	f	g	h
i	j	k	l	m	n	o	p	q	r
s	t	u	v	w	x	y	z	{	
}	→	!	"	#	\$	%	&	'	(
)	*	+	,	-	.	/	0	1	2
3	4	5	6	7	8	9	:	;	<
=	>	?	@						

When you have finished typing the new password, the last ENTER enters it. A verification screen appears. The screen will prompt you to retype your password for verification.

**A A A A A**  
**Retype PWD To Verify**

Wait a moment for the entry (<ENT>) screen. You will be given clearance to proceed.

**A A A A A**  
**<ENT> TO Proceed**

ENTER the letters of your new password. Your password will be stored in the microprocessor and the system will immediately switch to the ANALYZE screen, and you now have access to all instrument functions.

If all alarms are defeated, the ANALYZE screen appears as:

**0.0 % Anlz**  
**Range: 0 — 100**

If an alarm is tripped, the second line will change to show which alarm it is:

**0.0 % Anlz**  
**AL—1**

**NOTE:** If you log off the system using the LOGOUT function in the MAIN MENU, you will now be required to re-enter the password to gain access to any of the functions except password (PWD).

## 4.5 The LOGOUT Function

By entering LOGOUT, you effectively log off the instrument, leaving the system protected against tampering until the password is reentered. To log out, scroll to place the LOGOUT function between the arrows, and ENTER to log out. The screen will display the message:

**Protected Until**  
**Password Reentered**

## 4.6 The VERSION Screen

Scroll through the MAIN MENU to VERSION, and ENTER. The screen displays the manufacturer, model, and software version information.

## 4.7 The SELF-TEST Function

The Model 3020M has a built-in self-testing diagnostic routine. Preprogrammed signals are sent through the power supply, output board and sensor circuit. The return signal is analyzed, and at the end of the test the status of each function is displayed on the screen, either as OK or as a number between 1 and 3. (See *System Self Diagnostic Test* in chapter 5 for number code.)

The self diagnostics are run automatically by the analyzer whenever the instrument is turned on, but the test can also be run by the operator at will. To initiate SELF-TEST during operation:

Use the DOWN/UP control to scroll through the MAIN MENU to SELF-TEST. The screen will follow the running of the diagnostic.

### **RUNNING DIAGNOSTIC Testing Preamp — 83**

During preamp testing there is a countdown in the lower right corner of the screen. When the testing is complete, the results are displayed.

**Power: OK   Analog: OK  
Preamp: 3**

The module is functioning properly if it is followed by OK. A number indicates a problem in a specific area of the instrument. Refer to Chapter 5 *Maintenance* for number-code information. The results screen alternates for a time with:

**Press Any Key  
To Continue...**

Then the analyzer returns to the ANALYZE screen.

## 4.8 The SPAN Functions

The analyzer is calibrated using span gas.

For optimum accuracy, we recommend the analyzer be spanned in the high range with span gas of a known oxygen concentration in the range of 70-90% of full scale.

Connect the calibration gases to the analyzer according to the instructions given in section 3.5, *Gas Connections*, observing all the prescribed precautions.

**Shut off the gas pressure before connecting it to the analyzer, and be sure to control the pressure to about 10 psig when turning it back on.**

Readjust the gas pressure into the analyzer until the flowrate (as read on the analyzer's SCCM flowmeter) settles at 700 cc/minute.

If you are using password protection, you will need to enter your password to gain access to either of these functions. Follow the instructions in section 4.4 to enter your password. Once you have gained clearance to proceed, you can ENTER the ZERO or SPAN function.

### 4.8.1 Span Cal

SPAN is used to span calibrate the analyzer. Span calibration can be performed using the **automatic** mode, where an internal algorithm compares consecutive readings from the sensor to determine when the output matches the span gas concentration. Span calibration can also be performed in **manual** mode, where the operator determines when the span concentration reading is acceptable and manually exits the function.

#### 4.8.1.1 Auto Mode Spanning

Scroll to SPAN, and ENTER the SPAN function. The screen that appears allows you to select whether the span calibration is to be performed automatically or manually. Use the DOWN/UP control to toggle between AUTO and MAN span settling. Stop when AUTO appears on the display.

```
Span: Settling: AUTO
<ENT> For Next
```

Use ENTER to move to the next screen.

```
Span Val: 20.90
<ENT>Span <UP>Mod #
```

Use DOWN/UP to start changing the oxygen-concentration. Use ESCAPE/ENTER to blink the digit you are going to modify. Use DOWN/UP again to change the value of the selected digit. When you have finished typing in the concentration of the span gas you are using, repeatedly select ENTER until the rightmost digit is reached, then, the next ENTER will exit the Span Val screen. One more ENTER will enter the new span value, bring up the next screen, and start the span calibration.

```
#### % Span
Slope=#### ppm/s
```

The beginning span value is shown in the upper left corner of the display. As the span reading settles, the screen displays and updates information on Slope. Spanning automatically ends when the span output corresponds, within tolerance, to the value of the span gas concentration. Then the instrument automatically returns to the ANALYZE mode.

### 4.8.1.2 Manual Mode Spanning

ENTER SPAN from the MAIN MENU to start the SPAN function. The screen that appears allows you to select whether the span calibration is to be performed automatically or manually.

**Span: Settling:MAN**  
**<ENT> For Next**

Use DOWN/UP to toggle between AUTO and MAN span settling. Stop when MAN appears on the display. Use ENTER to move to the next screen.

**Span Val: 20.90**  
**<ENT>Span <UP>Mod #**

Use UP to permit modification (Mod #) of span value.

Use ESCAPE/ENTER to choose the digit, and use DOWN/UP to choose the value of the digit.

When you have finished typing in the concentration of the span gas you are using, repeatedly select ENTER until the rightmost digit is reached, then, the next ENTER will exit the Span Val field. One more ENTER will enter the new span value, bring up the next screen, and start the span calibration.

Once the span has begun, the microprocessor samples the output at a predetermined rate. It calculates the difference between successive samplings and displays this difference as Slope on the screen. It takes several seconds for the first Slope value to display. Slope indicates rate of change of the Span reading. It is a sensitive indicator of stability.

**#### % Span**  
**Slope=#### ppm/s**

When the Span value displayed on the screen is sufficiently stable, ENTER it. (Generally, when the Span reading changes by 1 % or less of the full scale of the range being calibrated for a period of ten minutes it is sufficiently stable.) Once you ENTER it, the Span reading changes to the correct value. The instrument then **automatically** enters the ANALYZE function.

## 4.9 Zero Cal

The ZERO function on the MAIN MENU is used to enter the zero calibration function. Zero calibration can be performed in either the automatic or manual mode. In the **automatic** mode, an internal algorithm compares consecutive readings from the sensor to determine when the output is within the acceptable range for zero. In the **manual** mode, the operator determines when the reading is within the acceptable range for zero.

Make sure the zero gas is connected to the instrument.



If you have trouble zeroing, you may need to skip to section 4.8.1.3 *Cell Failure*.

### Auto Mode Zeroing

Select ZERO to enter the ZERO function. The ZERO screen allows you to select whether the zero calibration is to be performed automatically or manually. Use the DOWN/UP control to toggle between AUTO and MAN zero settling. Stop when AUTO appears on the display.

**Zero: Settling: AUTO**  
**<ENT> To Begin**

ENTER to begin zeroing.

#### % Zero  
Slope=#### ppm/s

The beginning zero level is shown in the upper left corner of the display. As the zero reading settles, the screen displays and updates information on Slope (unless the Slope starts within the acceptable zero range and does not need to settle further).

Then, and whenever Slope is less than 0.08 for at least 3 minutes, instead of Slope you will see a countdown, such as 1 Left, 0 Left. These are steps in the zeroing process that the system must complete, AFTER settling, before it can go back to ANALYZE.

#### % Zero  
1 Left=### ppm/s

The zeroing process will automatically conclude when the output is within the acceptable range for a good zero. Then the analyzer automatically returns to the ANALYZE screen.

### Manual Mode Zeroing

ENTER the ZERO function. The screen that appears allows you to select between automatic or manual zero calibration. Use DOWN/UP to toggle between AUTO and MAN zero settling. Stop when MAN appears on the display.

**Zero: Settling: Man**  
**<ENT> To Begin**

ENTER to begin the zero calibration. After a few seconds the first of five zeroing screens appears. The number in the upper left hand corner is the first-stage zero offset. The microprocessor samples the output at a predetermined rate. It calculates the differences between successive samplings and

displays the rate of change as Slope= a value in parts per million per second (ppm/s).

#### % Zero  
Slope=#### ppm/s

**NOTE: It takes several seconds for the true Slope value to display. Wait about 10 seconds. Then, wait until Slope is sufficiently close to zero before using ENTER to finish zeroing.**

Generally, you have a good zero when Slope is less than 0.05 ppm/s for about 30 seconds. When Slope is close enough to zero, ENTER it. In a few seconds, the screen will update.

Once zero settling completes, the information is stored in the microprocessor, and the instrument automatically returns to the ANALYZE screen.

## 4.10 The ALARMS Function

The Model 3020M is equipped with 2 fully adjustable concentration alarms and a system failure alarm. Each alarm has a relay with a set of form "C" contacts rated for 3 amperes resistive load at 250 V ac. See Figure in Chapter 3, *Installation* and/or the Interconnection Diagram included at the back of this manual for relay terminal connections.

The system failure alarm has a fixed configuration described in chapter 3 *Installation*.

The concentration alarms can be configured from the front panel as either *high* or *low* alarms by the operator. The alarm modes can be set as *latching* or *non-latching*, and either *failsafe* or *non-failsafe*, or, they can be *defeated* altogether. The setpoints for the alarms are also established using this function.

Decide how your alarms should be configured. The choice will depend upon your process. Consider the following four points:

1. Which if any of the alarms are to be high alarms, and which if any are to be low alarms?

Setting an alarm as HIGH triggers the alarm when the oxygen concentration rises above the setpoint. Setting an alarm as LOW triggers the alarm when the oxygen concentration falls below the setpoint.

Decide whether you want the alarms to be set as:

- Both high (high and high-high) alarms, or

- One high and one low alarm, or
  - Both low (low and low-low) alarms.
2. Are either or both of the alarms to be configured as failsafe?

In failsafe mode, the alarm relay de-energizes in an alarm condition. For non-failsafe operation, the relay is energized in an alarm condition. You can set either or both of the concentration alarms to operate in failsafe or non-failsafe mode.

3. Are either of the alarms to be latching?

In latching mode, once the alarm or alarms trigger, they will remain in the alarm mode even if process conditions revert back to non-alarm conditions. This mode requires an alarm to be recognized before it can be reset. In the non-latching mode, the alarm status will terminate when process conditions revert to non-alarm conditions.

4. Are either of the alarms to be defeated?

The defeat alarm mode is incorporated into the alarm circuit so that maintenance can be performed under conditions which would normally activate the alarms.

The defeat function can also be used to reset a latched alarm. (See procedures, below.)

If you are using password protection, you will need to enter your password to access the alarm functions. Follow the instructions in section 4.4 to enter your password. Once you have clearance to proceed, ENTER the ALARM function.

**AL-1 AL-2**  
**Choose Alarm**

Use the DOWN/UP control to blink your choice of alarm, AL-1 or AL-2. Then ENTER to move to the next screen.

**AL-1 1.00 % HI**  
**Dft-N Fs-N Ltch-N**

Five parameters can be changed on this screen.

- Value of the alarm setpoint: AL-1 ##### % (oxygen)
- Out-of-range direction: HI or LO
- Defeated? (Yes/No): Dft-Y/N
- Failsafe? (Yes/No): Fs-Y/N
- Latching? (Yes/No): Ltch-Y/N.
- To define the setpoint, use ENTER to blink AL-1 #####, if not already blinking. Then use the DOWN/UP control to change the

number. Holding the control on the DOWN or UP position, while the number changes, speeds up the incrementing or decrementing. (Remember, the setpoint units are always % O<sub>2</sub>.)

- To set the other parameters use ENTER to blink the desired parameter. Then use DOWN/UP to change the parameter.
- Once the parameters for the alarm have been set, ENTER the ALARM function again, and repeat this procedure for next alarm.
- To reset a latched alarm:  
Go to Dft– and then assert either DOWN two times or UP two times. (Toggle it to Y and then back to N.)

–OR –

Go to Ltch– and then assert either DOWN two times or UP two times. (Toggle it to N and back to Y.)

**Note:** In this screen, ENTER moves you through the fields and ESCAPE takes you back to the previous screen.

## 4.11 The RANGE Function

The RANGE function allows the operator to program up to three concentration ranges to correlate with the DC analog outputs. If no ranges are defined by the user, the instrument defaults to:

Low = 0–5 %  
Med = 0–25 %  
High = 0–100%.

The Model 3020M is set at the factory to default to autoranging. In this mode, the microprocessor automatically responds to concentration changes by switching ranges for optimum readout sensitivity. If the current range limits are exceeded, the instrument will automatically shift to the next higher range. If the sample concentration falls below the full scale of the next lower range, the instrument will switch to that range. A corresponding shift in the DC percent-of-range output, and in the range ID outputs, will be noticed.

The autoranging feature can be overridden so that analog output stays on a fixed range regardless of the oxygen concentration detected. If the concentration exceeds the upper limit of the range, the DC output will saturate at 1 VDC or 20 mA at the current output.

However, the digital readout and the RS-232 output of the concentration are unaffected by the fixed range. They continue to read accurately with full precision. See *Front Panel* description in Chapter 1.

The automatic air calibration range is always 0-25 % and is not programmable.

#### 4.11.1 Setting the Analog Output Ranges

To set the ranges, ENTER the RANGE function mode by selecting RANGE from the MAIN MENU. The RANGE screen appears.

L—5.00 M—25.00  
H—100.00 Mode—AUTO

Use the DOWN/UP control to the range to be set: low (L), medium (M), or high (H).

Use the DOWN/UP control to enter the upper value of the range (all ranges begin at 0 %). Repeat for each range you want to set. ENTER to accept the values and return to the *Analysis Mode*. (See note below.)

**Note:** The ranges must be increasing from low to high, for example, if range 1 is set as 0–10 % and range 2 is set as 0–100 %, range 3 cannot be set as 0–25 % since it is lower than range 2.

#### 4.11.2 Automatic Ranging

After defining your analysis ranges, set Mode— to AUTO, if not already there. ESCAPE to re-enter the ANALYZE screen using the fixed range.

#### 4.11.3 Fixed Range Analysis

The autoranging mode of the instrument can be overridden, forcing the analyzer DC outputs to stay in a single predetermined range.

To switch from autoranging to fixed range analysis, ENTER the RANGE function by selecting RANGE from the MAIN MENU.

Use the DOWN/UP control to move AUTO between the arrows.

Use the DOWN/UP control to switch from AUTO to FX/LO, FX/MED, or FX/HI to set the instrument on the desired fixed range (low, medium, or high).

L—5.00 M—25.00  
H—100.00 Mode—FX/LO

OR

L—5.00 M—25.00  
H—100.00 Mode—FX/MED

OR

L—5.00 M—25.00  
H—100.00 Mode—FX/HI

ESCAPE to re-enter the ANALYZE screen using the fixed range.

**Note:** When performing analysis on a fixed range, if the oxygen concentration rises above the upper limit, as established by the setup, for that particular range, the output saturates at 1 V dc (20 mA at optional mA dc output). However, the digital readout and the RS-232 output continue to read the true value of the oxygen concentration regardless of the analog output range.

Contrast Function is *DISABLED*  
(Refer to Section 1.6)



## 4.12 The CONTRAST Function

If you cannot read anything on the display after first powering up:

1. Observe LED readout.
  - a. If LED meter reads all **eights and dots**, go to step 3.
  - b. If LED meter displays anything else, go to step 2.
2. Disconnect power to the Analyzer and reconnect again. LED meter should now read all eights and dots.

## 4.13 The STANDBY Function

In STANDBY, the analyzer's internal circuits are powered, but there are no displays or outputs from the analyzer.

**WARNING:** *THE POWER CABLE MUST BE UNPLUGGED TO FULLY DISCONNECT POWER FROM THE INSTRUMENT. WHEN THE ACCESS DOOR IS OPEN AND THE POWER CABLE IS CONNECTED, EXTRA CARE IS REQUIRED TO AVOID CONTACT WITH LIVE ELECTRICAL CIRCUITS.*



**CAUTION:** *If you disconnect the primary power source from the analyzer, then on re-energizing, you will be required to choose to keep the configuration you previously programmed into your instrument in the Setup Mode, or it will reset to factory defaults.*



Use **STANDBY** whenever you want to power down without danger losing all of the configuration you programmed into your instrument in the *Setup Mode*.

#### 4.14 The *Analysis Mode*

This is the normal operating mode of the analyzer. In this mode the analyzer is monitoring the sample, measuring and displaying the amount of oxygen, and reporting alarm conditions.

Normally, the Version, Self-Test, Sensor, Main Menu, and the Span and Zero (in auto-settling mode) functions automatically switch back to the *Analysis Mode* ANALYZE screen when they have completed their assigned operations. After four or five seconds in the MAIN MENU without any action by the operator, the analyzer automatically switches itself back to the ANALYZE screen. ESCAPE, asserted one or more times, depending on the starting point, also switches the analyzer back to the ANALYZE screen.

#### 4.15 Sensor Function

Not Used on the 3020M. This function tests micro-fuel sensor output on the 3020 for those that are using it.

## Maintenance

---

### 5.1 Routine Maintenance



Aside from normal cleaning and checking for leaks at the gas connections, routine maintenance is limited to replacing Paramagnetic Sensor and fuses, and recalibration. For recalibration, see Section 4.4 *The Zero and Span Functions*.



**WARNING:** SEE WARNINGS ON TITLE PAGE OF THIS MANUAL.

### 5.2 Major Internal Components

All internal components are accessed by unbolting and swinging open the front cover, as described earlier. The major internal component locations are shown in Figure 5-1, and the fuse receptacle is shown in Figure 5-2.

The 3020M contains the following major internal components:

- Paramagnetic Sensor
- Paramagnetic Sensor 24Vdc Power Supply
- Customer Interface PCB (Power Supply on bottom surface)
- Preamp PCB (Contains Microprocessor)
- Front Panel PCB (Contains Displays)
  - 5 digit LED meter
  - 2 line, 20 character, alphanumeric, VFD display
- Solenoid Operated Gas Control Valves (–C option only).



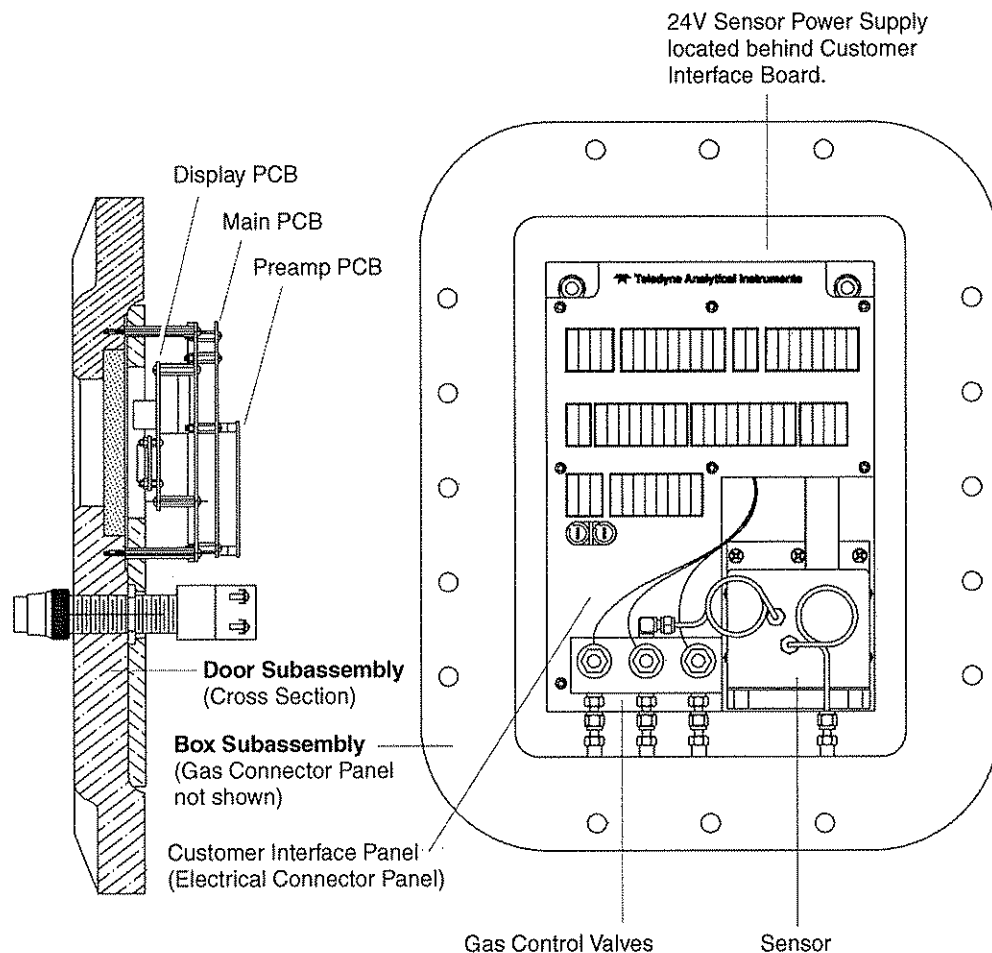

Figure 5-1: Major Internal Components

To swing open the cover panel, remove all screws.

### 5.3 Sensor Replacement

The Paramagnetic Sensor is maintenance free, and has a long life. Should the sensor fail, contact the factory for service and replacement.

### 5.4 Fuse Replacement

The 3020M requires two 5 x 20 mm, 4 A, T type (Slow Blow) fuses. The fuses are located inside the explosion proof housing on the Electrical Connector Panel, as shown in Figure 5-2. To replace a fuse:

1. Disconnect the Unit from its power source.
2. Place a small screwdriver in the notch in the fuse holder cap, push in, and rotate 1/4 turn. The cap will pop out a few millimeters. Pull out the fuse holder cap and fuse, as shown in Figure 5-3.

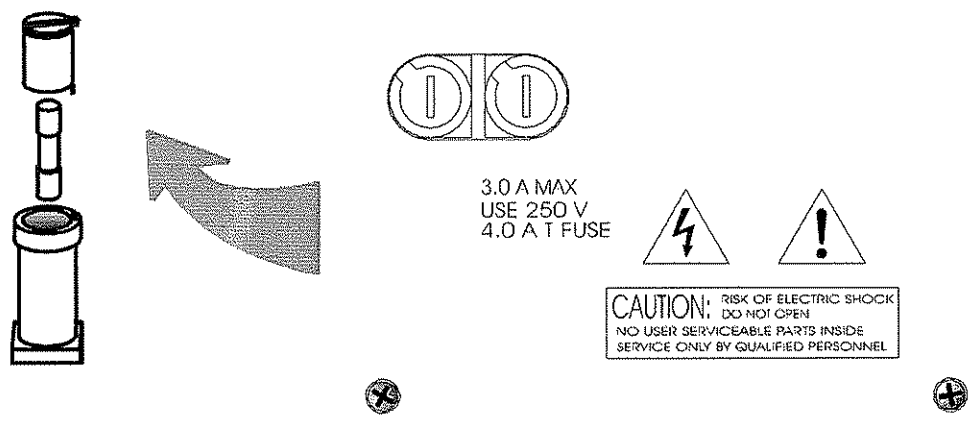

Figure 5-2: Removing Fuse Cap and Fuse from Holder

2. Replace fuse by reversing process in step 1.

## 5.5 System Self Diagnostic Test

Use the DOWN/UP control to scroll through the MAIN MENU to SELF-TEST. The screen will follow the running of the diagnostic.

**RUNNING DIAGNOSTIC**  
**Testing Preamp – 83**

During preamp testing there is a countdown in the lower right corner of the screen. When the testing is complete, the results are displayed.

**Power: OK Analog: OK**  
**Preamp: 3**

The module is functioning properly if it is followed by OK. A number indicates a problem in a specific area of the instrument. Refer to Table 5-1 for number-code information. The results screen alternates for a time with:

**Press Any Key**  
**To Continue...**

The following failure codes apply:

**Table 5-1: Self Test Failure Codes**

Power	
0	OK
1	5 V Failure
2	15 V Failure
3	Both Failed

**Analog**

- 0 OK
- 1 DAC A (0–1 V Concentration)
- 2 DAC B (0–1 V Range ID)
- 3 Both Failed

**Preamp**

- 0 OK
- 1 Zero too high
- 2 Amplifier output doesn't match test input
- 3 Both Failed

Note that preamp test does not tell anything about sensor condition. If preamp is ok but instrument is not performing then sensor, sensor power supply, and sensor interconnection cable are suspects.

## 5.6 Output Goes Negative

If during operation of the instrument, gas pressure exceeds 20 psig, the output of the sensor may reverse polarity, readings on the display may go negative. If this happens:

Make sure analyzer is mounted in the upright position (see chapter 3, Installation).

Turn power off by unplugging the instrument.

Turn gas pressure to less than 20 psig.

Turn power on again.

Return instrument to analyze mode.

---

## Appendix

---

### A-1 Specifications

**Packaging:** Explosion-proof. Bulkhead mount.

**Sensor:** Paramagnetic Sensor.

**Ranges:** Three user definable ranges from 0-5 % to 0-100 %.

Autoranging with range ID output.

**Sample System:** Flow indicator visible from front of unit.

Positive pressure service.

Vacuum service (optional).

Auto Cal / Auto Zero. (Available with optional, electrically operated valves.)

**Alarms:** One system-failure alarm contact to detect power failure.

Two adjustable concentration threshold alarms with fully programmable setpoints.

**Diagnostics:** Start-up or on-demand self-testing function.

**Response Time:** 90% in 10 seconds or less.

**Displays:** 2 line by 20 alphanumeric, VFD screen, and one 5 digit LED display.

**Digital Interface:** Full duplex RS-232 communications port.

**Power:** Universal power supply 100-240 V ac, at 50 or 60 Hz, 70 Watts max.

**Operating Temperature:** 0-45 °C

**Accuracy:**  $\pm 1\%$  of full scale at constant temperature.  
 $\pm 5\%$  of full scale over operating temperature range, on factory default analysis ranges, once thermal equilibrium has been achieved.

**Analog outputs:** 0-1 V dc percent-of-range  
0-1 V dc range ID.

4-20 mADC percent-of-range  
4-20 mADC range ID.

**Password Access:** Can be user-configured for password protection.

## A-2 Recommended 2-Year Spare Parts List

QTY.	PART NUMBER	DESCRIPTION
1	C62371B	Display PCB
1	D70046	Customer Interface PCB
1	C70043	Percent Preamplifier Board
1	C73870-A	Main PCB (4-20 mA)
4	F1295	Fuse, 4A, 250V, 5x20 mm, T (Slow Blow)

A minimum charge is applicable to spare parts orders.

**Note:** Orders for replacement parts should include the part number (if available) and the model and serial number of the instrument for which the parts are intended.

Orders should be sent to:

Teledyne Analytical Instruments  
16830 Chestnut Street  
City of Industry, CA 91749-1580

Phone (626) 934-1500, Fax (626) 961-2538  
TWX (910) 584-1887 TDYANYL COID

Web: [www.teledyne-ai.com](http://www.teledyne-ai.com)

or your local representative.

## A-3 Drawing List

D-70000 Outline Drawing  
D-69991 Wiring Diagram  
B-69990 Piping Diagram  
C-69989 Interconnection Diagram

**NOTE:** The MSDS on this material is available upon request through the Teledyne Environmental, Health and Safety Coordinator. Contact at (626) 934-1592

## A-5 Zero Cal

The ZERO function on the MAIN MENU is used to enter the zero calibration function. Zero calibration can be performed in either the automatic or manual mode. In the **automatic** mode, an internal algorithm compares consecutive readings from the sensor to determine when the output is within the acceptable range for zero. In the **manual** mode, the operator determines when the reading is within the acceptable range for zero.

Make sure the zero gas is connected to the instrument.

If you have trouble zeroing, you may need to skip to section 4.8.1.3 *Cell Failure*.

### Auto Mode Zeroing

Select ZERO to enter the ZERO function. The ZERO screen allows you to select whether the zero calibration is to be performed automatically or manually. Use the DOWN/UP control to toggle between AUTO and MAN zero settling. Stop when AUTO appears on the display.

**Zero: Settling: AUTO**  
**<ENT> To Begin**

ENTER to begin zeroing.

#### % Zero  
Slope=#### ppm/s

The beginning zero level is shown in the upper left corner of the display. As the zero reading settles, the screen displays and updates information on Slope (unless the Slope starts within the acceptable zero range and does not need to settle further).

Then, and whenever Slope is less than 0.08 for at least 3 minutes, instead of Slope you will see a countdown, such as 1 Left, 0 Left. These are steps in the zeroing process that the system must complete, AFTER settling, before it can go back to ANALYZE.

#### % Zero  
1 Left=### ppm/s

The zeroing process will automatically conclude when the output is within the acceptable range for a good zero. Then the analyzer automatically returns to the ANALYZE screen.



### Manual Mode Zeroing

ENTER the ZERO function. The screen that appears allows you to select between automatic or manual zero calibration. Use DOWN/UP to toggle between AUTO and MAN zero settling. Stop when MAN appears on the display.

**Zero: Settling: Man  
<ENT> To Begin**

ENTER to begin the zero calibration. After a few seconds the first of five zeroing screens appears. The number in the upper left hand corner is the first-stage zero offset. The microprocessor samples the output at a predetermined rate. It calculates the differences between successive samplings and displays the rate of change as Slope= a value in parts per million per second (ppm/s).

#### % Zero  
Slope=#### ppm/s

**NOTE: It takes several seconds for the true Slope value to display.**

**Wait about 10 seconds. Then, wait until Slope is sufficiently close to zero before using ENTER to finish zeroing.**

Generally, you have a good zero when Slope is less than 0.05 ppm/s for about 30 seconds. When Slope is close enough to zero, ENTER it. In a few seconds, the screen will update.

Once zero settling completes, the information is stored in the microprocessor, and the instrument automatically returns to the ANALYZE screen.



NOTES: UNLESS OTHERWISE SPECIFIED.

1. ALL DIMENSIONS ARE IN INCHES (±.06) AND MILLIMETERS (±1.1) INCHES[mm]

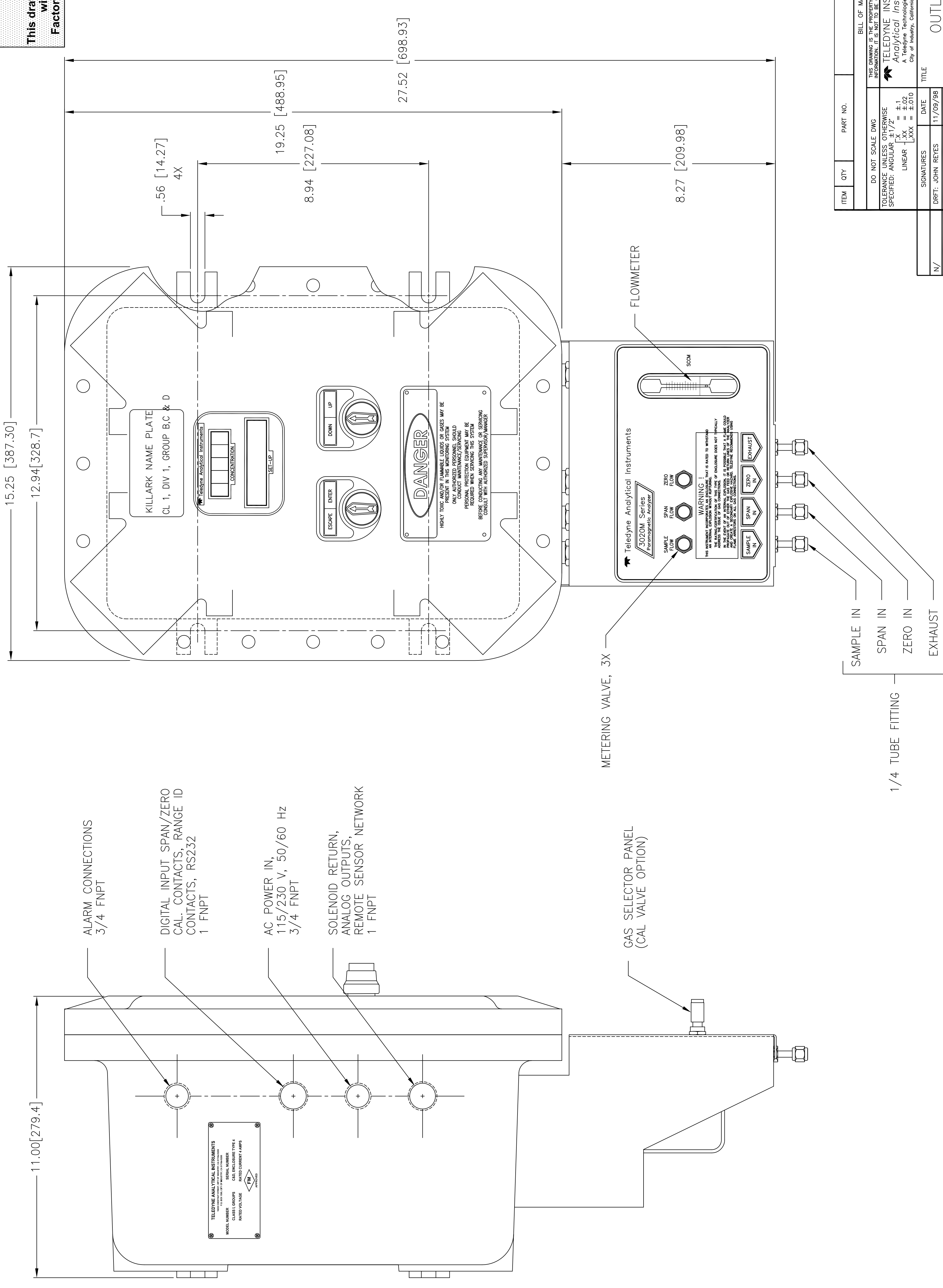

- ALARM CONNECTIONS  
3/4 FNPT
- DIGITAL INPUT SPAN/ZERO  
CAL. CONTACTS, RANGE ID  
CONTACTS, RS232  
1 FNPT
- AC POWER IN,  
115/230 V, 50/60 Hz  
3/4 FNPT
- SOLENOID RETURN,  
ANALOG OUTPUTS,  
REMOTE SENSOR NETWORK  
1 FNPT

GAS SELECTOR PANEL  
(CAL VALVE OPTION)

METERING VALVE, 3X

1/4 TUBE FITTING

- SAMPLE IN
- SPAN IN
- ZERO IN
- EXHAUST

**FM**  
This drawing must not be changed  
without the approval of  
Factory Mutual Research Corp.

REV	DESCRIPTION	DATE	APP.	REV.
0	REL. PER ECO# 98-0569	04/07/99	TMc	--
1	INC ECO 99-0249	12/1/00	AA	JCR

ITEM	QTY	PART NO.	DESCRIPTION
BILL OF MATERIAL			
DO NOT SCALE DWG			
TOLERANCE UNLESS OTHERWISE SPECIFIED: ANGULAR ±1/2°			
LINEAR [XXX] ±.02			
[XXX] ±.010			
SIGNATURES DATE TITLE			
DRAFT: JOHN REYES	11/09/98		
CHK:			
APPR:			
ENGR: TIM MCINTYRE			
C.O. STANDARD			
REFERENCE: CAD ID: D70000-1			
MATERIAL: NONE			DWG. NO. <b>D-70000</b>
SCALE: 1:2			SIM D-65909
TITLE: OUTLINE DIAGRAM PARAMAGNETIC UNIT MODEL 3020M			SHEET 1 OF 1
REV. 1			REV. 1



NOTES: UNLESS OTHERWISE SPECIFIED.

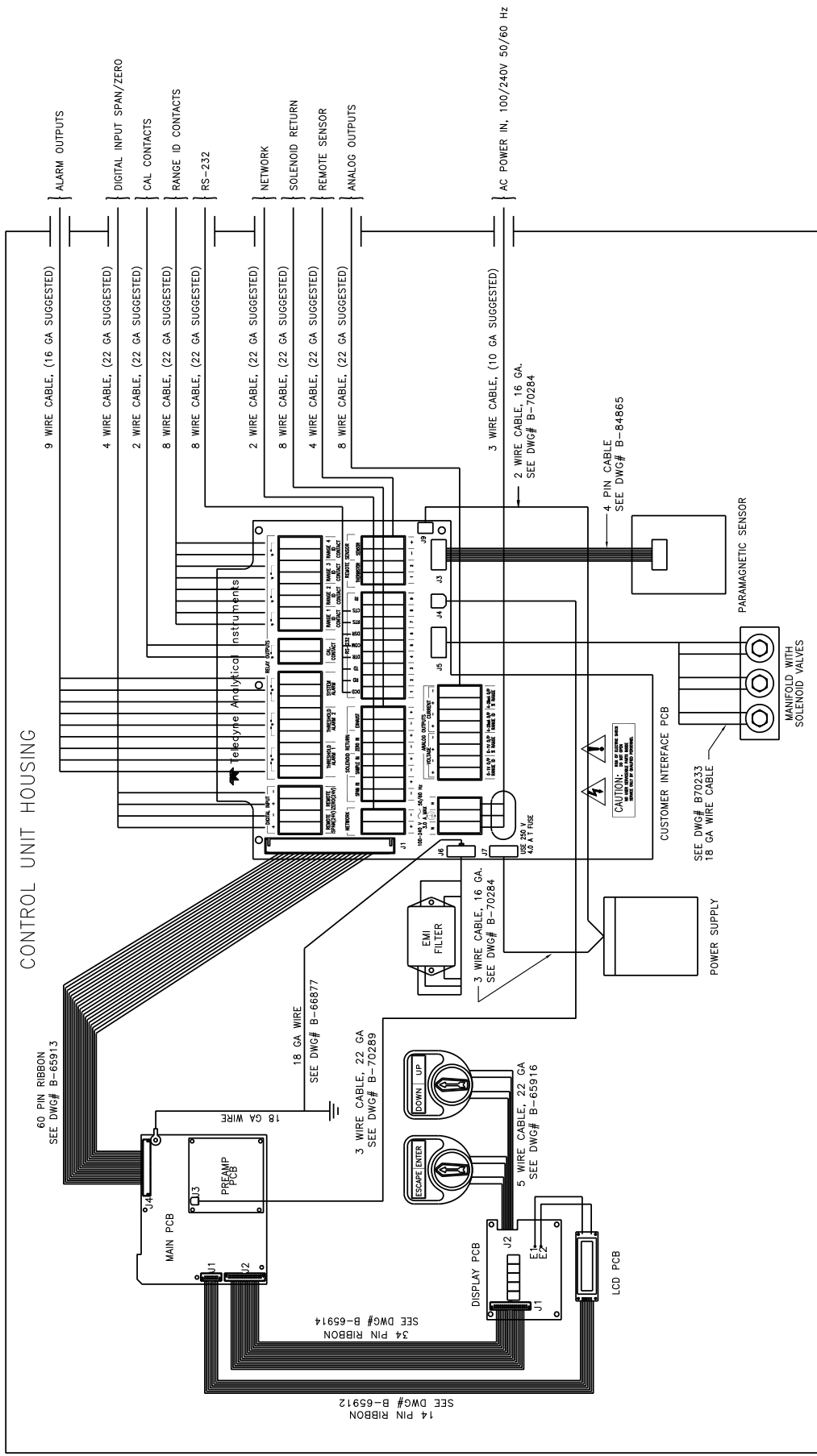

REV	DESCRIPTION	DATE	APP.	REV.
0	REL PER ECO# 98-0569	3/19/99	TM	--
1	INC ECO 10-0222	11/10/10	KFP	VF
2	INC ECO 13-0015	2/4/13	SB	VF

- ALARM OUTPUTS
- DIGITAL INPUT SPAN/ZERO
- CAL CONTACTS
- RANGE ID CONTACTS
- RS-232
- NETWORK
- SOLENOID RETURN
- REMOTE SENSOR
- ANALOG OUTPUTS
- AC POWER IN, 100/240V 50/60 Hz

UNLESS OTHERWISE SPECIFIED  
DIMENSIONS ARE IN INCHES  
TOLERANCE  
ANGULAR ±1/2° LINEAR ±.010

TELEDYNE  
A Division of Teledyne Instruments, Inc.  
A Business Unit of Teledyne Instruments  
City of Industry, California 91748, USA

INTERCONNECTION DIAGRAM  
PARAMAGNETIC UNIT  
MODEL 3020M

SIGNATURES	DATE	TITLE	SCALE	NONE
DRT: JOHN REYES	11/11/98		SIM	C-69968
CHK:			SHEET	1 OF 1
APP: P/B-69990			REV	2
ENGR: O/D-70000			DWG NO.	C-69989
C.O.: F/D-69993			MATL	NOTED
REFERENCE				



NOTES: UNLESS OTHERWISE SPECIFIED.



APPROVED

REV	DESCRIPTION	DATE	APP.	REV.
0	REL. PER ECO# 98-0569	3/19/99	TM	--
1	INC. PER ECO# 01-0256	10/23/01	AA	JCR
2	INC. PER ECO 10-0222	11/10/10	KFP	VF

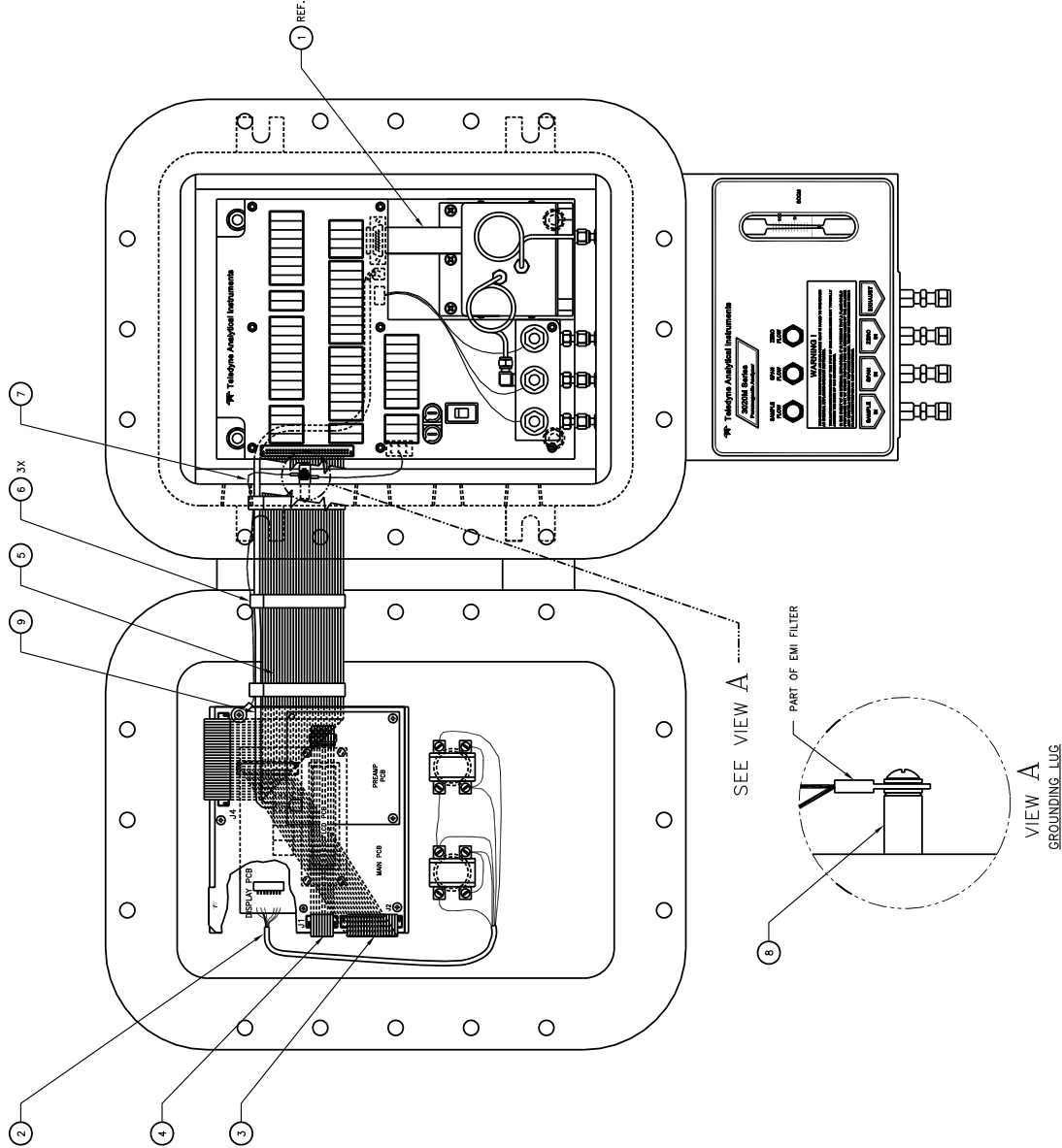

ITEM	QTY	PART NO.	DESCRIPTION
9	1	B70289	CABLE ASSY. SENSOR INTERCONNECT
8	REF	S 1110	SPACER (PART OF D-69922)
7	REF	C70398	EMI FILTER AND GROUNDING WIRE ASSEMBLY
6	3	CP 1787	CABLE CLIP
5	1	B65913	RIBBON CABLE ASSY
4	1	B65912	RIBBON CABLE ASSY (MAIN PCB - DISPLAY PCB)
3	1	B65914	WIRING ASSY (MAIN PCB - DISPLAY PCB)
2	1	B65916	WIRING ASSY (CONTROL SWITCHES - DISPLAY PCB)
1	REF	B84865	CABLE ASSEMBLY (SENSORS)

TITLE OF MATERIAL	
NO. 303 SCALE CHANGES	THIS DRAWING IS THE PROPERTY OF TELETYPE INSTRUMENTS AND CANNOT BE REPRODUCED WITHOUT THE WRITTEN PERMISSION OF TELETYPE INSTRUMENTS
UNLESS OTHERWISE SPECIFIED	ALL DIMENSIONS ARE IN INCHES
UNLESS OTHERWISE SPECIFIED	FINISHES ARE AS SHOWN
UNLESS OTHERWISE SPECIFIED	STANDARD TOLERANCES ARE AS FOLLOWS
FRAMES	FRACTIONAL DECIMALS
HOLES	DECIMALS
ANGLES	DEGREES
THREADS	AS SHOWN
UNLESS OTHERWISE SPECIFIED	ALL DIMENSIONS ARE IN INCHES
UNLESS OTHERWISE SPECIFIED	FINISHES ARE AS SHOWN
UNLESS OTHERWISE SPECIFIED	STANDARD TOLERANCES ARE AS FOLLOWS
FRAMES	FRACTIONAL DECIMALS
HOLES	DECIMALS
ANGLES	DEGREES
THREADS	AS SHOWN

DATE	11/17/98
DRAWN BY	JOHN REYES
CHECKED BY	TM MONTYRE
APPROVED BY	TM MONTYRE
ENGINEER	TM MONTYRE
CONTRACT NO.	STANDARD
PROJECT NO.	D-69991-2

SCALE	1:2
SHEET NO.	D-69067
TITLE	WIRING ASSEMBLY PARAMAGNETIC UNIT MODEL 3020M
DATE	11/17/98
DRAWN BY	JOHN REYES
CHECKED BY	TM MONTYRE
APPROVED BY	TM MONTYRE
ENGINEER	TM MONTYRE
CONTRACT NO.	STANDARD
PROJECT NO.	D-69991-2

AS LISTED	D-69991
AS LISTED	D-69991
AS LISTED	D-69991

SCALE	1:2
SHEET NO.	D-69067
TITLE	WIRING ASSEMBLY PARAMAGNETIC UNIT MODEL 3020M
DATE	11/17/98
DRAWN BY	JOHN REYES
CHECKED BY	TM MONTYRE
APPROVED BY	TM MONTYRE
ENGINEER	TM MONTYRE
CONTRACT NO.	STANDARD
PROJECT NO.	D-69991-2

AS LISTED	D-69991
AS LISTED	D-69991
AS LISTED	D-69991

SCALE	1:2
SHEET NO.	D-69067
TITLE	WIRING ASSEMBLY PARAMAGNETIC UNIT MODEL 3020M
DATE	11/17/98
DRAWN BY	JOHN REYES
CHECKED BY	TM MONTYRE
APPROVED BY	TM MONTYRE
ENGINEER	TM MONTYRE
CONTRACT NO.	STANDARD
PROJECT NO.	D-69991-2

AS LISTED	D-69991
AS LISTED	D-69991
AS LISTED	D-69991

SCALE	1:2
SHEET NO.	D-69067
TITLE	WIRING ASSEMBLY PARAMAGNETIC UNIT MODEL 3020M
DATE	11/17/98
DRAWN BY	JOHN REYES
CHECKED BY	TM MONTYRE
APPROVED BY	TM MONTYRE
ENGINEER	TM MONTYRE
CONTRACT NO.	STANDARD
PROJECT NO.	D-69991-2

AS LISTED	D-69991
AS LISTED	D-69991
AS LISTED	D-69991

SCALE	1:2
SHEET NO.	D-69067
TITLE	WIRING ASSEMBLY PARAMAGNETIC UNIT MODEL 3020M
DATE	11/17/98
DRAWN BY	JOHN REYES
CHECKED BY	TM MONTYRE
APPROVED BY	TM MONTYRE
ENGINEER	TM MONTYRE
CONTRACT NO.	STANDARD
PROJECT NO.	D-69991-2

AS LISTED	D-69991
AS LISTED	D-69991
AS LISTED	D-69991

SCALE	1:2
SHEET NO.	D-69067
TITLE	WIRING ASSEMBLY PARAMAGNETIC UNIT MODEL 3020M
DATE	11/17/98
DRAWN BY	JOHN REYES
CHECKED BY	TM MONTYRE
APPROVED BY	TM MONTYRE
ENGINEER	TM MONTYRE
CONTRACT NO.	STANDARD
PROJECT NO.	D-69991-2

AS LISTED	D-69991
AS LISTED	D-69991
AS LISTED	D-69991

SCALE	1:2
SHEET NO.	D-69067
TITLE	WIRING ASSEMBLY PARAMAGNETIC UNIT MODEL 3020M
DATE	11/17/98
DRAWN BY	JOHN REYES
CHECKED BY	TM MONTYRE
APPROVED BY	TM MONTYRE
ENGINEER	TM MONTYRE
CONTRACT NO.	STANDARD
PROJECT NO.	D-69991-2

AS LISTED	D-69991
AS LISTED	D-69991
AS LISTED	D-69991

SCALE	1:2
SHEET NO.	D-69067
TITLE	WIRING ASSEMBLY PARAMAGNETIC UNIT MODEL 3020M
DATE	11/17/98
DRAWN BY	JOHN REYES
CHECKED BY	TM MONTYRE
APPROVED BY	TM MONTYRE
ENGINEER	TM MONTYRE
CONTRACT NO.	STANDARD
PROJECT NO.	D-69991-2

AS LISTED	D-69991
AS LISTED	D-69991
AS LISTED	D-69991

SCALE	1:2
SHEET NO.	D-69067
TITLE	WIRING ASSEMBLY PARAMAGNETIC UNIT MODEL 3020M
DATE	11/17/98
DRAWN BY	JOHN REYES
CHECKED BY	TM MONTYRE
APPROVED BY	TM MONTYRE
ENGINEER	TM MONTYRE
CONTRACT NO.	STANDARD
PROJECT NO.	D-69991-2

AS LISTED	D-69991
AS LISTED	D-69991
AS LISTED	D-69991

SCALE	1:2
SHEET NO.	D-69067
TITLE	WIRING ASSEMBLY PARAMAGNETIC UNIT MODEL 3020M
DATE	11/17/98
DRAWN BY	JOHN REYES
CHECKED BY	TM MONTYRE
APPROVED BY	TM MONTYRE
ENGINEER	TM MONTYRE
CONTRACT NO.	STANDARD
PROJECT NO.	D-69991-2

AS LISTED	D-69991
AS LISTED	D-69991
AS LISTED	D-69991





NOTES: UNLESS OTHERWISE SPECIFIED.

REVISIONS

REV	DESCRIPTION	DATE	APP.	REV. BY
0	REL. PER ECO# 98-0569	3/19/99	TM	--

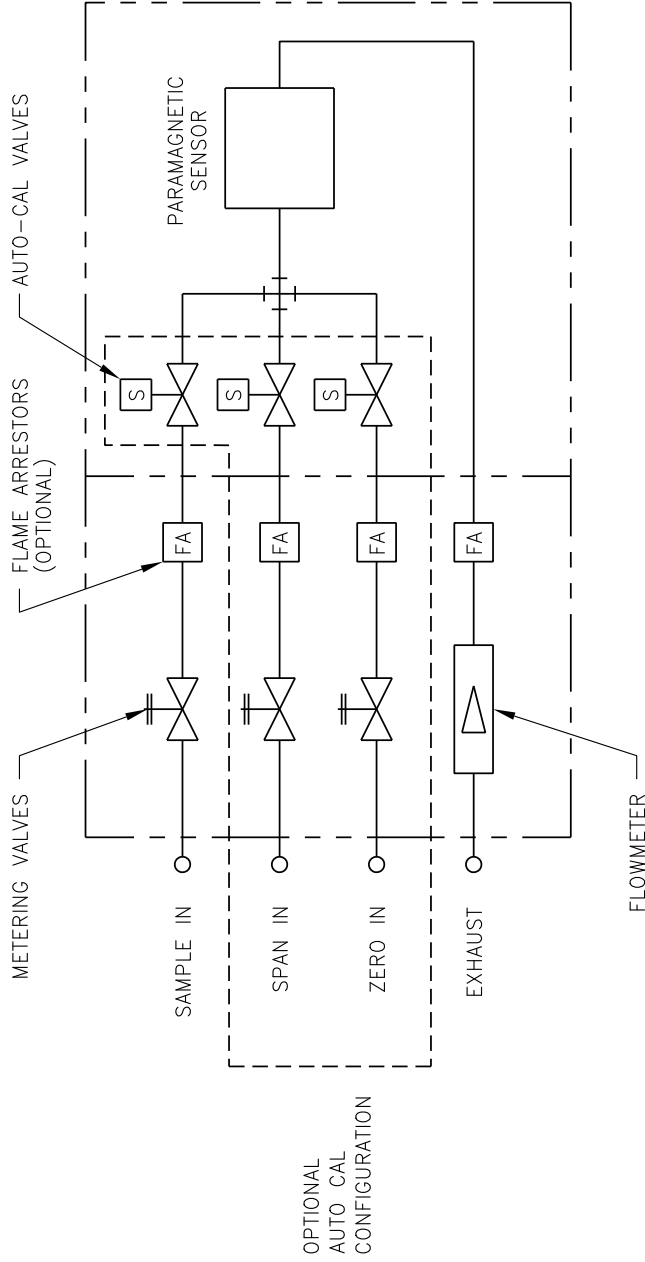

ITEM	QTY	PART No.	DESCRIPTION
BILL OF MATERIAL			
THIS DRAWING IS THE PROPERTY OF TELEDYNE ANALYTICAL INSTRUMENTS AND CONTAINS CONFIDENTIAL INFORMATION. IT IS NOT TO BE COPIED, REPRODUCED OR USED WITHOUT WRITER PERMISSION.			
DO NOT SCALE DWG		TELEDYNE ELECTRONIC TECHNOLOGIES Analytical Instruments An Allegheny Teledyne Company CITY OF INDUSTRY, CALIFORNIA 91748	
TOLERANCE UNLESS OTHERWISE SPECIFIED: ANGULAR ±1/2°		SCALE NONE	
LINEAR { .X = ±.1 .XX = ±.02 .XXX = ±.010		SIM NONE	
SIGNATURES	DATE	TITLE	
DRFT: JOHN REYES	11/09/98	PIPING DIAGRAM PARAMAGNETIC UNIT MODEL 3020M	
CHK:		SHEET 1 OF 1	
APPR:		REV	
ENGR: TIM McINTYRE		0	
S.O.: STANDARD		DWG NO. B-69990	
REFERENCE		MATERIAL: NONE	
		CAD I.D. B69990-0	